



ESSA RESEARCH LABORATORIES

Institute for Telecommunication Sciences
Boulder, Colorado
October 1969

UHF Buried Antenna Path Loss Measurements

L. G. HAUSE
F. G. KIMMETT

Final Report Phase C Part 9
In Support of Hard Rock Silo Development
Program 125B
Contract F04701-68-F-0072
Task 2.7h



Technical Memorandum ERLTM-ITS 206

U.S. DEPARTMENT OF COMMERCE / ENVIRONMENTAL SCIENCE SERVICES ADMINISTRATION

**ESSA RESEARCH LABORATORIES
INSTITUTE FOR TELECOMMUNICATION SCIENCES**

Distribution Of This Report Is Unlimited.



IMPORTANT NOTICE

Technical Memoranda are used to insure prompt dissemination of special studies which, though of interest to the scientific community, may not be ready for formal publication. Since these papers may later be published in a modified form to include more recent information or research results, abstracting, citing, or reproducing this paper in the open literature is not encouraged. Contact the author for additional information on the subject matter discussed in this Memorandum.

ENVIRONMENTAL SCIENCE SERVICES ADMINISTRATION

BOULDER, COLORADO

SAMSO-TR-69-261

U.S. DEPARTMENT OF COMMERCE
Environmental Science Services Administration
Research Laboratories

ESSA Technical Memorandum ERLTM-ITS 206

UHF BURIED ANTENNA PATH LOSS MEASUREMENTS

L. G. Hause
F. G. Kimmett

Distribution of this document is Unlimited.

Institute for Telecommunication Sciences
Boulder, Colorado
October 1969



SAMSO-TR-69-261

ABSTRACT

UHF BURIED ANTENNA PATH LOSS MEASUREMENTS

L. G. Hause and F. G. Kimmett

Ground-to-ground path loss measurements are tabulated and discussed for paths terminated in surface and buried antennas, with and without security fences. Both horizontally and vertically polarized antennas at 415.9 MHz were used. Path lengths varied from 15 m to 17 km, and depths ranged from 0 to -2.25m. Conical pits 3 m deep were dug into the earth and filled with fuel oil, which served as a homogeneous dielectric surrounding the antennas and formed a smooth, level boundary layer at the surface. Data showing the effect of off-path, terrain reflections on transmission loss between low antennas are presented.

TABLE OF CONTENTS

	Page
ABSTRACT	1
1. INTRODUCTION	1
2. PATH GEOMETRY AND SITE CONFIGURATIONS	2
3. EQUIPMENT AND OPERATIONS	3
4. INVESTIGATION OF OFF-PATH REFLECTIONS	4
5. RESULTS AND COMPARISONS	5
6. CONCLUSIONS AND RECOMMENDATIONS	9
7. ACKNOWLEDGEMENTS	10
8. REFERENCES	10
APPENDIX. UHF Antennas for Subsurface Tests	44

UHF BURIED ANTENNA PATH LOSS MEASUREMENTS

L. G. Hause and F. G. Kimmett

Ground-to-ground path loss measurements are tabulated and discussed for paths terminated in surface and buried antennas, with and without security fences. Both horizontally and vertically polarized antennas at 415.9 MHz were used. Path lengths varied from 15 m to 17 km, and depths ranged from 0 to -2.25 m. Conical pits 3 m deep were dug into the earth and filled with fuel oil, which served as a homogeneous dielectric surrounding the antennas and formed a smooth, level boundary layer at the surface. Data showing the effects of off-path, terrain reflections on transmission loss between low antennas are presented.

Key Words; Boundary layer, buried antennas, path loss measurements, security fences.

1. INTRODUCTION

During August 1968, UHF path loss measurements were made in Wyoming with one antenna buried in Sherman granite and another in broken weathered rock. The terrain between sites was irregular. Vertically polarized antennas omnidirectional in the horizontal plane were used. For additional details on these tests, see Hause et al. (1969). As a result of these and other investigations, a need for additional measurements covering a greater range of conditions was recognized to answer the following questions:

- (1) What is the effect of burying the antenna more than 1 m deep?
- (2) How does transmission loss vary as a function of depth?
- (3) Can transmission loss for buried antennas be calculated accurately for most paths?

- (4) What are the effects of changing the polarization and orientation of simple dipole antennas?
- (5) What changes in path loss values should we expect from placing a security fence around the antenna?

This set of experiments was designed to answer these and other questions. To vary the antenna depth continuously, it was decided to use a liquid dielectric. Because the dielectric constant and conductivity of water varies markedly with small changes of temperature and ion content, fuel oil was selected. A liquid dielectric provides the additional benefit of forming a homogeneous medium around the antenna, which would not be provided by broken rock or sand with varying moisture content. The cone-shaped pit that held the dielectric was configured so that the critical angle would occur at the air-liquid boundary over most of the depth range.

The tests were selected to be compatible with two current theoretical sutides, allowing direct comparison between theoretical and measured results. In the interest of reporting the measurement values at the earliest possible date, the discussion of these comparisons was deferred.

2. PATH GEOMETRY AND SITE CONFIGURATIONS

Plan views of the test paths are shown in figures 1 and 2. The three path profiles are shown in figure 3. From the profile for R_a to T_a , it is apparent that this path is not line of sight for low antennas. Figures 2, 4, and 6 are down path photographs of the three test paths.

The Table Mountain test area is a remnant of a former glacial outwash plain consisting of gravel and large rocks. Two conical pits were dug at sites R_a and T_a (fig. 2). They were approximately 3.5 m in diameter and 3 m deep (fig. 7). Similar pits were dug at sites T_b and T_c (fig. 1) and were spanned by 2 in x 6 in wooden beams covered

with 1/2 in plywood. The antennas were lowered through an opening in the center to various depths. The gravel and rocks removed from the pits were graded and smoothed over the adjacent area.

Seven-foot, nine-gauge chain link fences topped by three strands of wire were placed 15 m downpath from the centers of R_a and T_a (fig. 8). These 20-m fence sections are easily erected. The fence sections run perpendicular to the path from R_a to T_a . No fence measurements were made from sites T_b and T_c .

3. EQUIPMENT AND OPERATIONS

Major equipment used were: a submersible transmitter, a high sensitivity receiver with a large dynamic range, a signal generator for receiver calibration, a 5-m fiber glass tripod, and three types of antennas.

Maximum power output of the transmitter when sealed was 5 W. The transmitter power amplifier and crystal-controlled oscillator were supplied with primary power by storage batteries, which were also contained within the sealed housing. Figures 9, 10, and 11 show the three types of antennas as used with the transmitter housing.

Preamplifiers for the receiver were housed in the same type of sealed container as the transmitter. Additional information concerning the receiver, signal generator, and transmitter are described by Hause et al. (1969).

The three types of antennas used were the quarter-wave monopole, the half-wave dipole, and the annular slot (see App.). The VSWR and patterns in air dielectric for these antennas change significantly when the antennas are submerged in fuel oil. Antenna patterns could not be accurately measured in the fuel oil because of reflections from the sides of the pit. In fuel oil, the monopole antenna was found to radiate 60 percent of the power corresponding to the forward traveling wave in the transmission line, the dipole 75 percent, and the slot antenna 29 percent.

For the measurements listed in table 1, the recorder was calibrated in terms of transmission loss, which is defined here as the ratio between the power radiated and the power received.

The dielectric constant and conductivity of fuel oil were measured for two samples: one obtained before and the other after the tests had been completed (see table 2). The tests began June 16 and ended July 22, 1969.

4. INVESTIGATION OF OFF-PATH REFLECTIONS

Expected signal levels were exceeded over the 2.4-km path at low antenna heights. Realizing the high signal levels probably would be caused by off-path reflections from objects subtending large elevation angles, we made measurements to determine the extent and the source of these secondary reflections. Two sets of measurements were completed from site T_a . First we determined the phase interference pattern produced by moving one of the antennas horizontally perpendicular to the path. The pattern is the result of the phase relationship between the reflected signals and the on-path signal at the various positions. This test was done once with the stationary antenna 0.75 m above ground and again with it 3 m above ground with the results shown in figure 13. The patterns can indicate the relative magnitude of the reflected signal with respect to the direct path signal, as well as the angle from the path to the secondary source, if the following conditions are met: (a) the secondary source must occur at a reasonably discrete angle and (b) the direct path signal must have a magnitude comparable with that of the reflection. Figure 13 shows that the lobe structure deepens when the stationary antenna is raised to the 3-m position, which indicates that the direct and reflected rays are more nearly equal at the 3-m position and that the reflected signal is dominate at the low

antenna heights. The distances measured between nulls indicates that the reflection lies between 75° and 90° from the path line.

The second investigation was made with a directive antenna having a horizontal beamwidth of approximately 50° (fig. 12). Moving the antenna 180° counter-clockwise from the downpath position indicated no reflections. Moving it from downpath toward the foothills indicated large reflections (fig. 14). The directions indicating large reflections contained no man-made obstacles.

Figure 2 is a contour map showing the angle containing maximum reflections within the 1-dB points. From the map, one can see that the hills subtending this angle rise approximately 1000 ft above the test plain. For the 0.75-m antenna heights, the curve in figure 14 shows the reflected signal approximately 7 dB greater than the direct path signal.

5. RESULTS AND COMPARISONS

The buried antenna and fence test parameters are defined in table 1. The curves resulting from these tests follow figure 14; they are labeled according to the test numbers in table 1. Most of the graphs are plots of transmission loss as a function of transmitter antenna height above ground. Electrical constants for granite and fuel oil are given in table 2.

The wooden pit covers described earlier were used to keep the fuel oil clean, for safety, and as a work platform. Because we suspected that these covers might significantly affect the test results, we investigated their effects. Tests 2 and 2a as well as 3 and 3a show that the covers produce very little effect (less than 1 dB). Tests 2b and 3b were conducted to determine the difference in transmission loss when the monopole antenna was suspended at zero antenna height over the pit and when it was placed in a 1-ft³ hole to the side of the pit at the

same antenna height. From tests 2b and 3b, it is apparent that this change in antenna location makes very little difference (approximately 1 dB), at least for small angle ground reflections.

In view of the results of the investigation of off-path reflections, it is apparent that the fence tests over the 2.41-km path have little significance; these tests are 7 through 10, 30, 31, and 37. The other fence tests, 11, 12, 26, and certain tests without fences, 1, 2, 3, 4, 24, and 25, are discussed in detail by Gierhart and Johnson (1969) and will not be considered further here.

Both the monopole and the dipole antenna radiate significantly at the negative elevation angles. As a result, deep lobing occurred as these antennas were lowered into the fuel oil. Reflections from the sides and bottom of the pit combined with the directly radiated fields produced the phase interference patterns shown by test curves 27 through 38. Curves 39 and 40, which are for the annular slot antenna, show much less interference effect because the slot antenna pattern was directed primarily upward. As a result of these observations, we recommend that in future tests of this type; elementary antennas should be backed by a reflector fixed at approximately $1/4$ wavelength or less under the elementary radiator to provide an upward directed antenna pattern.

The reflections at the dielectric-soil interface would be much reduced for an interface of concrete and soil compared with fuel oil and soil, because the dielectric discontinuity between soil and concrete is much less.

A number of tests were made at Table Mountain with the pits containing only air. The Wyoming test (Hause et al., 1969) indicated that there might be little difference in transmission loss between when the hole is filled with air and when it is filled with another dielectric. We have ample opportunity to compare such cases here. The following

test pairs are applicable: 14-28, 15-32, 16-33, 17-34, 18-35, 19-36, 20-38, 21-39, and 22-40. Pairs 14-28, 15-32, 16-33, 17-34, 19-36, and 20-38 were difficult to compare because of the phase interference patterns, caused primarily by side and bottom reflections, but an average curve through each set of lobes separates the air and fuel oil loss condition by only a few dB (3 to 4), the transmission loss for the fuel oil being 3 to 4 dB greater than for air. However, comparisons between air and fuel oil for the annular slot antenna (21-39 and 22-40) show decided disagreement. Considering these results, the testing of proposed buried antenna configurations in empty holes does not seem suitable.

Test 33a, which is a measure of the vertically polarized component above ground received from a buried horizontally polarized antenna oriented parallel to the propagation path, is best compared with a corresponding point on test 27 for a vertical monopole buried at the same depth. The lobe structures resulting from the phase interference patterns make comparisons difficult, but comparing zero transmitting height losses for 33a with the same point on curve 27 shows a 9-dB greater loss for the horizontal dipole than for the vertical monopole. We consider this comparison inconclusive since tests 32, 33, and 34 show the horizontal dipole to be producing a null at the -1 m position.

Test 42 was made to determine the best orientation of a horizontal dipole to minimize transmission loss. For the dipoles oriented parallel to the path the loss is approximately 5 dB lower than for orientation perpendicular to the path at the 1-m depth. Comparison of tests 33 and 36 indicates at least this much difference at other depths. For the 8.5-km path, tests 74 and 76 indicate that the perpendicular orientation is 9 dB better than the parallel orientation. Tests 74 and 76 were done twice to permit greater confidence in the data. The measurement results were repeatable. These counter results for the

two paths probably indicate that where off-path reflection is the mechanism of propagation, orientation of the dipoles cannot be counted on for enhancing a particular path unless the, usually impractical, investigation of off-path reflections is completed first.

The transmission loss for monopoles 0.75 m above ground was used as a reference for comparison with the annular slot antenna. This reference was selected because of the large body of transmission loss data obtained at 0.75 m above ground (Hause et al., 1969). For the 2.4-km path with both monopoles 0.75 m above ground, the transmission loss was 136 dB (test 5). For the 8.5-km path, it was 129 dB (test 62). For the 2.4-km path with both annular slots 1 m deep in the fuel oil, the transmission loss was 156 dB (test 40). For the 8.5-km path, it was 149 dB (test 79). There is a 20-dB difference in transmission loss between the paths with the annular slot antennas and their corresponding reference for both comparisons. Curves 39 and 40 also show how the transmission loss increases as the slot antennas are further immersed into the dielectric (approximately 6 dB per meter). A similar comparison between the monopoles 1 m deep (test 27) and the 2.4-km path reference (test 5) shows a 31-dB difference. This result is far less pessimistic (from a communications standpoint) than the 81-dB difference observed for paths with the holes filled with broken rock (Hause et al., 1969).

The results of test 41 are not presented graphically because receiver system sensitivity was insufficient as a result of the poor impedance match for the slot antenna submerged in fuel oil. The transmission loss changed from 164 dB at zero height to approximately 175 dB at the 2-m depth.

The tests over the 17.1-km path provided few quantitative results. The path loss for antennas below ground exceeded the loss-measuring capability of our equipment. These data are shown in table 1 (tests 43 through 61).

6. CONCLUSIONS AND RECOMMENDATIONS

The results discussed in sections 4 and 5 lead to the following conclusions:

- (1) When low antennas are used, off-path terrain reflections can be the dominant mechanism of propagation in rough terrain. Security fences may increase the dominance of these reflections. The probability that the dominant means of propagation are from terrain reflections increases rapidly as the antenna height above ground decreases. This is especially applicable to heights of less than 3 m.
- (2) Usually, for both communications and testing, only antennas having predominantly upward directed patterns should be used in the buried antenna configuration within the 230- to 400-MHz band.
- (3) In rough terrain, the orientation effect of a buried horizontal dipole on transmission loss is seldom practical to predict at UHF.
- (4) The transmission loss between monopole antennas 0.75 m above ground is about 20 dB less than the loss for annular slot antennas 1 m below the surface.
- (5) As the depth of the annular slot antennas increases, the transmission loss increases approximately 6 dB per meter of depth.
- (6) The tests with the antennas immersed in a homogeneous dielectric indicate that earlier measurements in broken rock are overly pessimistic (Hause et al., 1969).

7. ACKNOWLEDGEMENTS





















This work was sponsored by the Air Force Systems Command, Space and Missile Systems Organization (SMQHN), Norton Air Force Base, California.

We wish to thank Mr. George Evers and Mr. Robert Juneau for their efforts in preparing and operating the many items of equipment used in these tests.

8. REFERENCES





- Bolljahn, J. T., and J. V. N. Granger (1961), Antenna Engineering Handbook, 1st ed., ed. Henry Jasik, chapters 27, 35-26 (McGraw-Hill Book Co., Inc., New York, N. Y.).
- Gierhart, G. D., and M. E. Johnson (1969), Effects of security fences on VHF/UHF propagation, ESSA Tech. Rept. ERLTM-ITS 196.
- Hause, L. G., F. G. Kimmett, and J. M. Harman (1969), UHF radio propagation data for low antenna heights, 1 and 2, ESSA Tech. Rept. (to be published).
- Kerr, D. E. (1964), Propagation of short radio waves, MIT Radiation Laboratory Series 13, (Boston Technical Publishers, Inc., Lexington, Mass.).
- Terman, Frederick E. (1955), Electronic and Radio Engineering, 4th ed., 919-920 (McGraw-Hill Book Co., Inc., New York, N. Y.).

Table 1. Buried Antenna and Security Fence Tests.

Test No.	Site Number		Path Dist. (km)	Antenna Height (m)		Covered With Fuel Oil		Antenna Type		Antenna Orientation		Range of Variable	Site With Fence in Place	Comments
	Xmtr	Rcvr		Xmtr	Rcvr	Xmtr	Rcvr	Xmtr	Rcvr	Xmtr	Rcvr			
1	Ra	Ra	0.015	vari.	0.75	No	No					0 to 3 m	None	
2	Ra	Ra	0.015	vari.	0	No	No					0 to 3 m	None	
2a	Ra	Ra	0.015	vari.	0	No	No					0 to 3 m	None	A
2b	Ra	Ra	0.015	vari.	0	No	No					0 to 3 m	None	B
3	Ra	Ra	0.03	vari.	0	No	No					0 to 3 m	None	
3a	Ra	Ra	0.03	vari.	0	No	No					0 to 3 m	None	A
3b	Ra	Ra	0.03	vari.	0	No	No					0 to 3 m	None	B
4	Ra	Ra	0.03	vari.	0.75	No	No					0 to 3 m	None	
5	Ta	Ra	2.41	vari.	0.75	No	No					0 to 3 m	None	
6	Ta	Ra	2.41	vari.	0	No	No					0 to 3m	None	

(Continued)

Symbols:

Vertical stub 
 Horizontal dipole 
 Annular slot 
 Perpendicular to path 
 Parallel to path 

Comments:

A - The plywood pit cover was removed.
 B - The receiving antenna was placed in a 1 ft³ depression to the side of the pit.

Table 1. Buried Antenna and Security Fences Tests (Continued)

Test No.	Site Number		Path Dist. (km)	Antenna Height (m)		Covered With Fuel Oil		Antenna Type		Antenna Orientation		Range of Variable	Site With Fence in Place	Comments
	Xmtr	Rcvr		Xmtr	Rcvr	Xmtr	Rcvr	Xmtr	Rcvr	Xmtr	Rcvr			
7	Ta	Ra	2.41	vari.	0	No	No	┆	┆			0 to 3 m	Ra Ta	
8	Ta	Ra	2.41	vari.	0.75	No	No	┆	┆			0 to 3 m	Ra Ta	
9	Ta	Ra	2.41	vari.	0.75	No	No	┆	┆			0 to 3 m	Ra	
10	Ta	Ra	2.41	vari.	0	No	No	┆	┆			0 to 3 m	Ra	
11	Ra	Ra	0.03	vari.	0	No	No	┆	┆			0 to 3 m	Ra	
12	Ra	Ra	0.03	vari.	0.75	No	No	┆	┆			0 to 3 m	Ra	
13	Ta	Ra	2.41	vari.	0.75	No	No	┆	┆			-2.0 to 0 m	None	
14	Ta	Ra	2.41	vari.	0	No	No	┆	┆			-2.0 to 0 m	None	
15	Ta	Ra	2.41	vari.	0	No	No	—	—	=	=	-2.0 to 0 m	None	
16	Ta	Ra	2.41	vari.	-1	No	No	—	—	=	=	-2.0 to 0 m	None	

(Continued)

Symbols:





- Vertical stub 
- Horizontal dipole 
- Annular slot 
- Perpendicular to path 
- Parallel to path 

Table 1. Buried Antenna and Security Fence Tests (Continued)

Test No.	Site Number		Path Dist. (km)	Antenna Height (m)		Covered With Fuel Oil		Antenna Type		Antenna Orientation		Range of Variable	Site With Fence in Place	Comments
	Xmtr	Rcvr		Xmtr	Rcvr	Xmtr	Rcvr	Xmtr	Rcvr	Xmtr	Rcvr			
17	Ta	Ra	2.41	vari.	-1.85	No	No	—	—	==	==	-2.0 to 0 m	None	
18	Ta	Ra	2.41	vari.	0	No	No	—	—	⊥	⊥	-2.0 to 0 m	None	
19	Ta	Ra	2.41	vari.	-1	No	No	—	—	⊥	⊥	-2.0 to 0 m	None	
20	Ta	Ra	2.41	vari.	-1.85	No	No	—	—	⊥	⊥	-2.0 to 0 m	None	
21	Ta	Ra	2.41	vari.	0	No	No	▽	▽			-2.0 to 0 m	None	
22	Ta	Ra	2.41	vari.	-1	No	No	▽	▽			-2.0 to 0 m	None	
23	Ta	Ra	2.41	vari.	-1.85	No	No	▽	▽			-2.0 to 0 m	None	
24	Ra	Ra	0.015	vari.	-1	No	Yes	⊥	⊥			0 to 3 m	None	
25	Ra	Ra	0.03	vari.	-1	No	Yes	⊥	⊥			0 to 3 m	None	
26	Ra	Ra	0.03	vari.	-1	No	Yes	⊥	⊥			0 to 3 m	Ra	

(Continued)

Symbols:



































- Vertical stub 
- Horizontal dipole 
- Annular slot 
- Perpendicular to path 
- Parallel to path 

Table 1. Buried Antenna and Security Fence Tests (Continued)

Test No.	Site Number		Path Dist. (km)	Antenna Height (m)		Covered With Fuel Oil		Antenna Type		Antenna Orientation		Range of Variable	Site With Fence in Place	Comments
	Xmtr	Rcvr		Xmtr	Rcvr	Xmtr	Rcvr	Xmtr	Rcvr	Xmtr	Rcvr			
27	Ta	Ra	2.41	vari.	-1	Yes	Yes					-2.0 to 0 m	None	
28	Ta	Ra	2.41	vari.	0	Yes	Yes					-2.0 to 0 m	None	
29	Ta	Ra	2.41	vari.	-1.85	Yes	Yes					-2.0 to 0 m	None	
30	Ta	Ra	2.41	vari.	-1	Yes	Yes					-2.0 to 0 m	Ra Ta	
31	Ta	Ra	2.41	vari.	-1	Yes	Yes					-2.0 to 0 m	Ra	
32	Ta	Ra	2.41	vari.	0	Yes	Yes					-2.0 to 0 m	None	
33	Ta	Ra	2.41	vari.	-1	Yes	Yes					-2.0 to 0 m	None	
33a	Ta	Ra	2.41	vari.	-1	Yes	Yes					0 to 3 m	None	
34	Ta	Ra	2.41	vari.	-1.85	Yes	Yes					-2.0 to 0 m	None	
35	Ta	Ra	2.41	vari.	0	Yes	Yes					-2.0 to 0 m	None	

(Continued)

Symbols:

Vertical stub



Horizontal dipole



Annular slot



Perpendicular to path



Parallel to path



Table 1. Buried Antenna and Security Fence Tests (Continued)

Test No.	Site Number		Path Dist. (km)	Antenna Height (m)		Covered With Fuel Oil		Antenna Type		Antenna Orientation		Range of Variable	Site With Fence in Place	Comments
	Xmtr	Rcvr		Xmtr	Rcvr	Xmtr	Rcvr	Xmtr	Rcvr	Xmtr	Rcvr			
36	Ta	Ra	2.41	vari.	-1	Yes	Yes	—	—	⊥	⊥	-2.0 to 0 m	None	
37	Ta	Ra	2.41	vari.	-1	Yes	Yes	—	—	⊥	⊥	-2.0 to 0 m	Ra Ta	
38	Ta	Ra	2.41	vari.	-1.85	Yes	Yes	—	—	⊥	⊥	-2.0 to 0 m	None	
39	Ta	Ra	2.41	vari.	0	Yes	Yes	▽	▽			-2.0 to 0 m	None	
40	Ta	Ra	2.41	vari.	-1	Yes	Yes	▽	▽			-2.0 to 0 m	None	
41	Ta	Ra	2.41	vari.	-1.85	Yes	Yes	▽	▽			-2.0 to 0 m	None	
42	Ta	Ra	2.41	-1	-1	Yes	Yes	—	—			0 to 90°	None	C
43	Tc	Ta	17.1	0.75	0.75	No	No	⊥	⊥				None	Trans. loss = 150 dB
44	Tc	Ta	17.1	0	0	No	No	⊥	⊥				None	Trans. loss 167 dB
45	Tc	Ta	17.1	-1	-1	No	No	⊥	⊥				None	Trans. loss > 185 dB

(Continued)

Symbols:

































Vertical stub
 Horizontal dipole
 Annular slot
 Perpendicular to path
 Parallel to path



Comments:

C - The antennas are held parallel and rotated in the horizontal plane.

Table 1. Buried Antenna and Security Fence Tests (Continued)

Test No.	Site Number		Path Dist. (km)	Antenna Height (m)		Covered With Fuel Oil		Antenna Type		Antenna Orientation		Range of Variable	Site With Fence in Place	Trans. Loss in dB
	Xmtr	Rcvr		Xmtr	Rcvr	Xmtr	Rcvr	Xmtr	Rcvr	Xmtr	Rcvr			
46	Tc	Ta	17.1	-2.0	-2.0	No	No						None	> 185
47	Tc	Ta	17.1	-1	-1	No	No						None	> 185
48	Tc	Ta	17.1	-2.0	-2.0	No	No						None	> 185
49	Tc	Ta	17.1	-1	-1	No	No						None	> 185
50	Tc	Ta	17.1	-2.0	-2.0	No	No						None	> 185
51	Tc	Ta	17.1	0	0	No	No						None	180
52	Tc	Ta	17.1	-1	-1	No	No						None	> 185
53	Tc	Ta	17.1	-2.0	-2.0	No	No						None	> 185
54	Tc	Ta	17.1	-1	-1	Yes	Yes						None	184
55	Tc	Ta	17.1	-1	-1	Yes	Yes						None	179

(Continued)

Symbols:

Vertical stub

Horizontal dipole

Annular slot

Perpendicular to path

Parallel to path



Table 1. Buried Antenna and Security Fence Tests (Continued)

Test No.	Site Number		Path Dist. (km)	Antenna Height (m)		Covered With Fuel Oil		Antenna Type		Antenna Orientation		Range of Variable	Site With Fence in Place	Trans. Loss in dB
	Xmtr	Rcvr		Xmtr	Rcvr	Xmtr	Rcvr	Xmtr	Rcvr	Xmtr	Rcvr			
56	Tc	Ta	17.1	-2.0	-2.0	Yes	Yes	—	—	==	==		None	183
57	Tc	Ta	17.1	-1	-1	Yes	Yes	—	—	⊥	⊥		None	180
58	Tc	Ta	17.1	-2.0	-2.0	Yes	Yes	—	—	⊥	⊥		None	183
59	Tc	Ta	17.1	0	0	Yes	Yes	▽	▽				None	>174
60	Tc	Ta	17.1	-1	-1	Yes	Yes	▽	▽				None	>174
61	Tc	Ta	17.1	-2.0	-2.0	Yes	Yes	▽	▽				None	>174
62	Tb	Ta	8.5	0.75	0.75	No	No	⊥	⊥				None	129
63	Tb	Ta	8.5	0	0	No	No	⊥	⊥				None	139
64	Tb	Ta	8.5	-1	-1	No	No	⊥	⊥				None	160
65	Tb	Ta	8.5	-2.0	-2.0	No	No	⊥	⊥				None	174

(Continued)

Symbols:

Vertical stub



Horizontal dipole



Annular slot



Perpendicular to path



Parallel to path



Table 1. Buried Antenna and Security Fence Tests (Continued)

Test No.	Site Number		Path Dist. (km)	Antenna Height (m)		Covered With Fuel Oil		Antenna Type		Antenna Orientation		Range of Variable	Site With Fence in Place	Trans. Loss in dB
	Xmtr	Rcvr		Xmtr	Rcvr	Xmtr	Rcvr	Xmtr	Rcvr	Xmtr	Rcvr			
66	Tb	Ta	8.5	-1	-1	No	No	—	—	==	==		None	178
67	Tb	Ta	8.5	-2.0	-2.0	No	No	—	—	==	==		None	>185
68	Tb	Ta	8.5	-1	-1	No	No	—	—	⊥	⊥		None	165
69	Tb	Ta	8.5	-2.0	-2.0	No	No	—	—	⊥	⊥		None	>185
70	Tb	Ta	8.5	0	0	No	No	▽	▽				None	145
71	Tb	Ta	8.5	-1	-1	No	No	▽	▽				None	165
72	Tb	Ta	8.5	-2.0	-2.0	No	No	▽	▽				None	169
73	Tb	Ta	8.5	-1	-1	Yes	Yes	—	—	⊥	==		None	168
74	Tb	Ta	8.5	-1	-1	Yes	Yes	—	—	==	==		None	167
75	Tb	Ta	8.5	-2.0	-2.0	Yes	Yes	—	—	==	==		None	175

(Continued)

Symbols:

Vertical stub

Horizontal dipole

Annular slot

Perpendicular to path

Parallel to path



Table 1. Buried Antenna and Security Fence Tests (Continued)

Test No.	Site Number		Path Dist. (km)	Antenna Height (m)		Covered With Fuel Oil		Antenna Type		Antenna Orientation		Range of Variable	Site With Fence in Place	Trans. Loss in dB
	Xmtr	Rcvr		Xmtr	Rcvr	Xmtr	Rcvr	Xmtr	Rcvr	Xmtr	Rcvr			
76	Tb	Ta	8.5	-1	-1	Yes	Yes	—	—	⊥	⊥		None	158
77	Tb	Ta	8.5	-2.0	-2.0	Yes	Yes	—	—	⊥	⊥		None	>185
78	Tb	Ta	8.5	0	0	Yes	Yes	▽	▽				None	143
79	Tb	Ta	8.5	-1	-1	Yes	Yes	▽	▽				None	149
80	Tb	Ta	8.5	-2.0	-2.0	Yes	Yes	▽	▽				None	158

- 19 -

Symbols:





- Vertical stub 
- Horizontal dipole 
- Annular slot 
- Perpendicular to path 
- Parallel to path 

Table 2. Electrical Constants for Materials.

Material	Frequency	Dielectric Constant	Critical Elevation Angle	Loss Tangent	Conductivity mhos/meter	Attenuation dB/meter	Information Source
Raymond granite	322.8 MHz	5.81	65.5°	.00915	.000952	.65	NBS tests on sample
Jet Fuel JP-1	300 MHz	2.12	46.2°	.0012	.00004	.05	Kerr, 1964
Fuel oil (before antenna tests)	415.9 MHz	2.26	48.4	.001	.00005	.06	NBS tests on sample
Fuel oil (after antenna tests)	415.9 MHz	2.27	48.4	.001	.00005	.06	NBS tests on sample

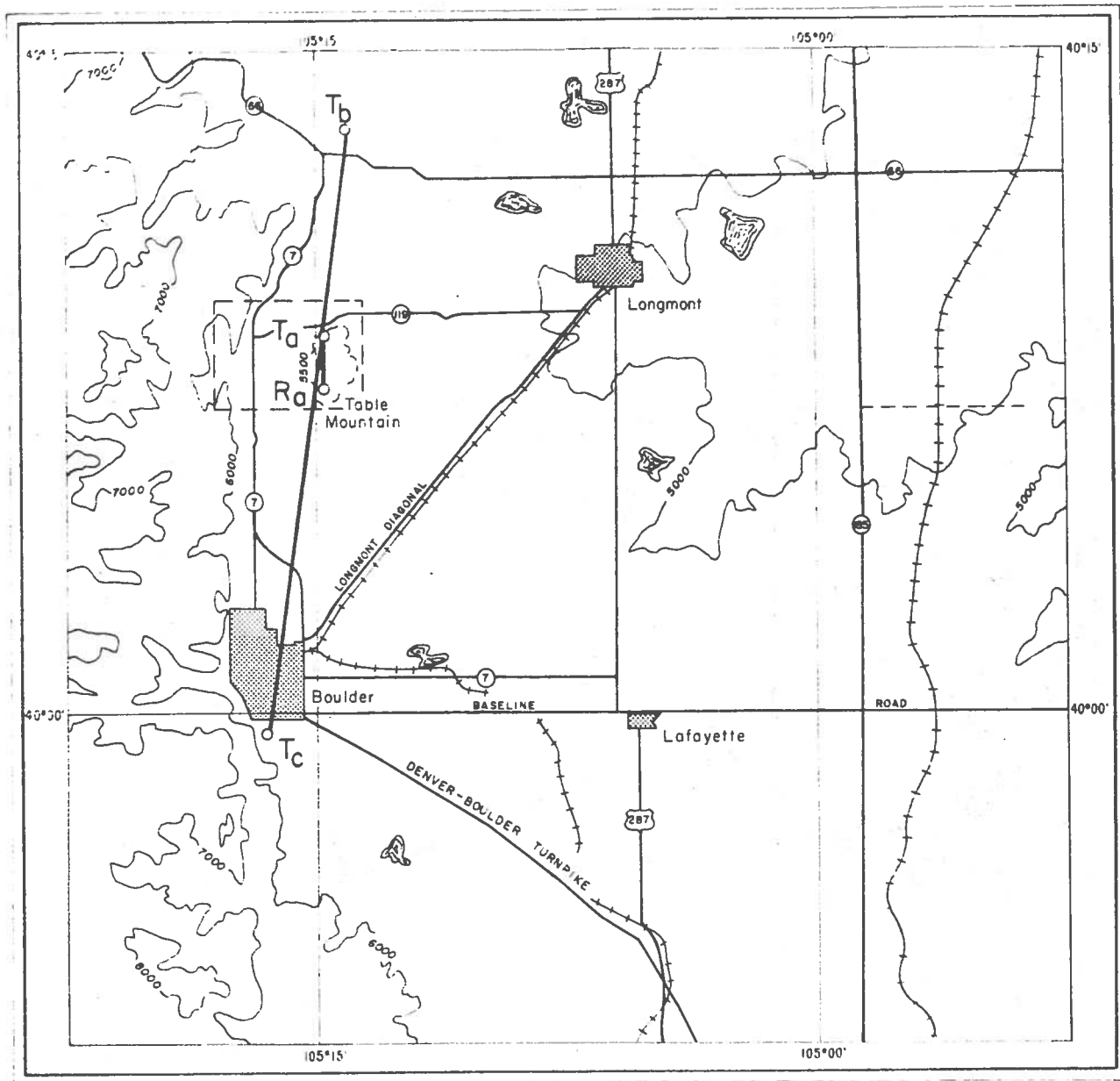

Figure 1. Colorado buried antenna test area.

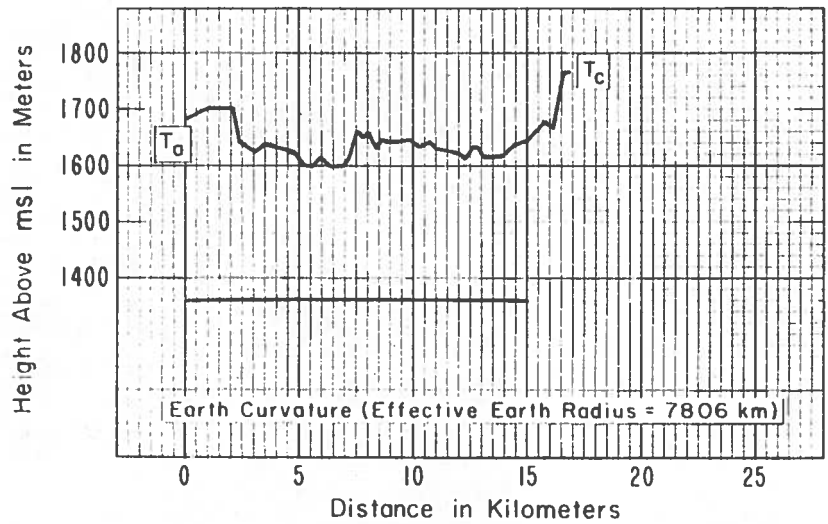
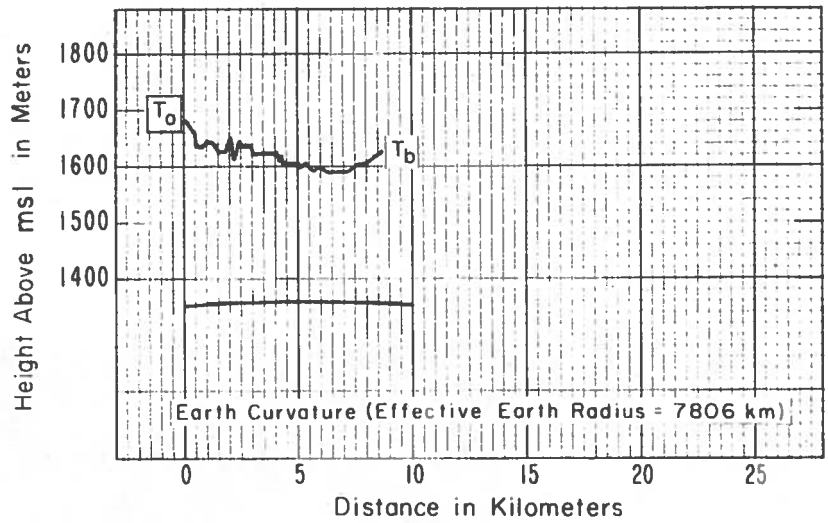
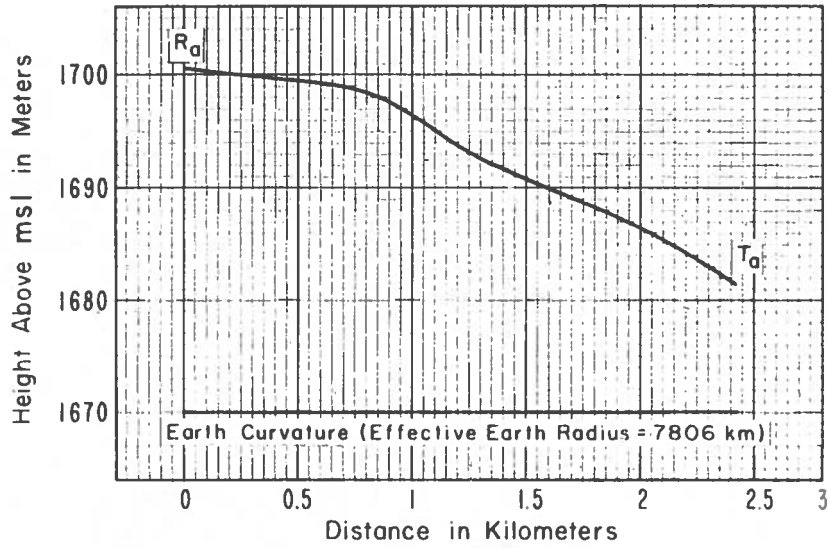
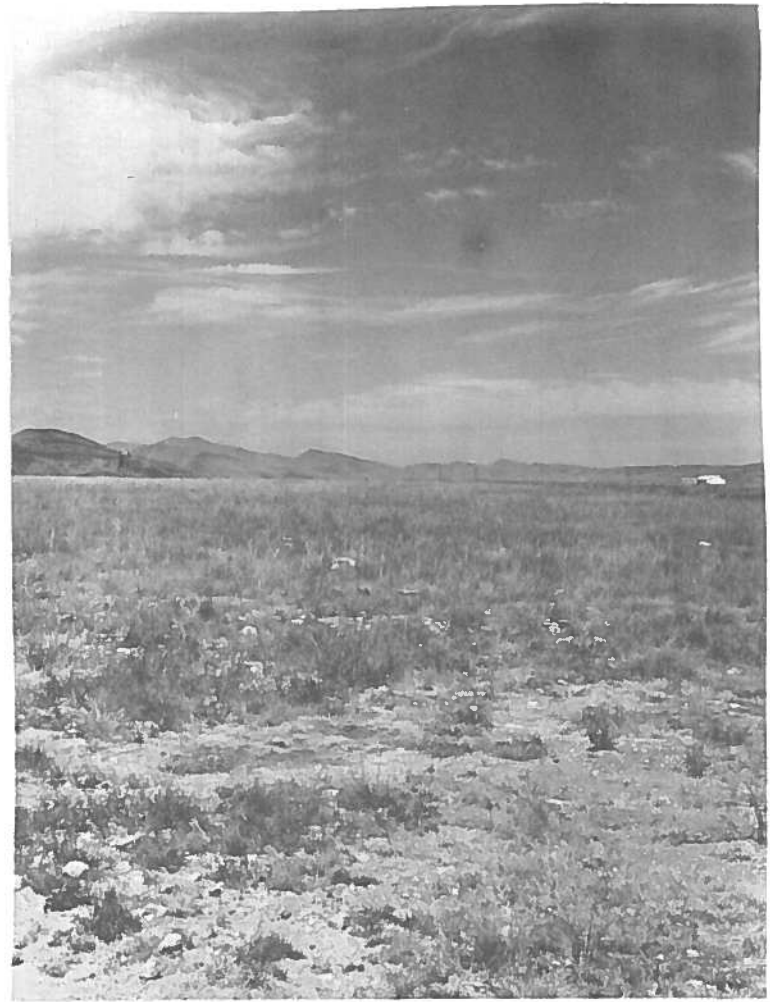

Figure 3. Buried antenna test path terrain profiles.



From Ta Toward Ra



From Ra Toward Ta

Figure 4. Downpath photographs for path Ra - Ta.



From Ta Toward Tb



From Tb Toward Ta

Figure 5. Downpath photographs for path Ta - Tb.



From Ta Toward Tc

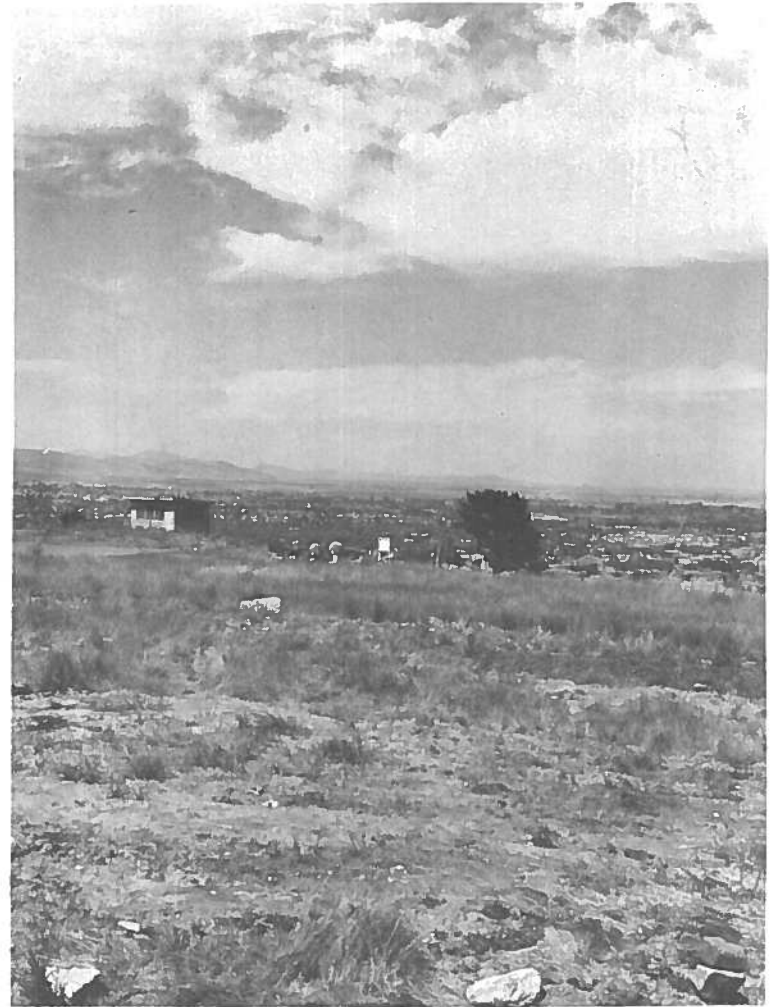

From Tc Toward Ta

Figure 6. Downpath photographs for path Ta - Tc.



Figure 7. The pit at site Ta.



Figure 8. Monopole antennas at site Ra for Test No.



Figure 9. Horizontal dipole and transmitter assembly.



Figure 10. Annular slot and transmitter assembly.



Figure 11. Monopole and transmitter assembly.

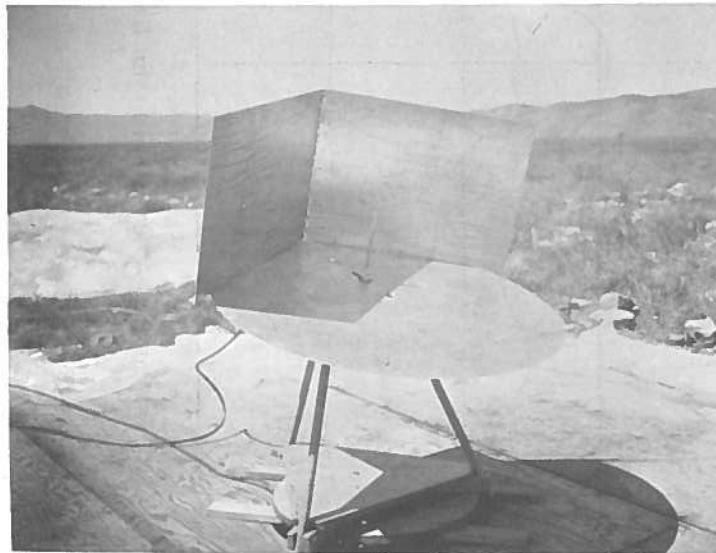

Figure 12. Directive antenna used to investigate off-path reflections.

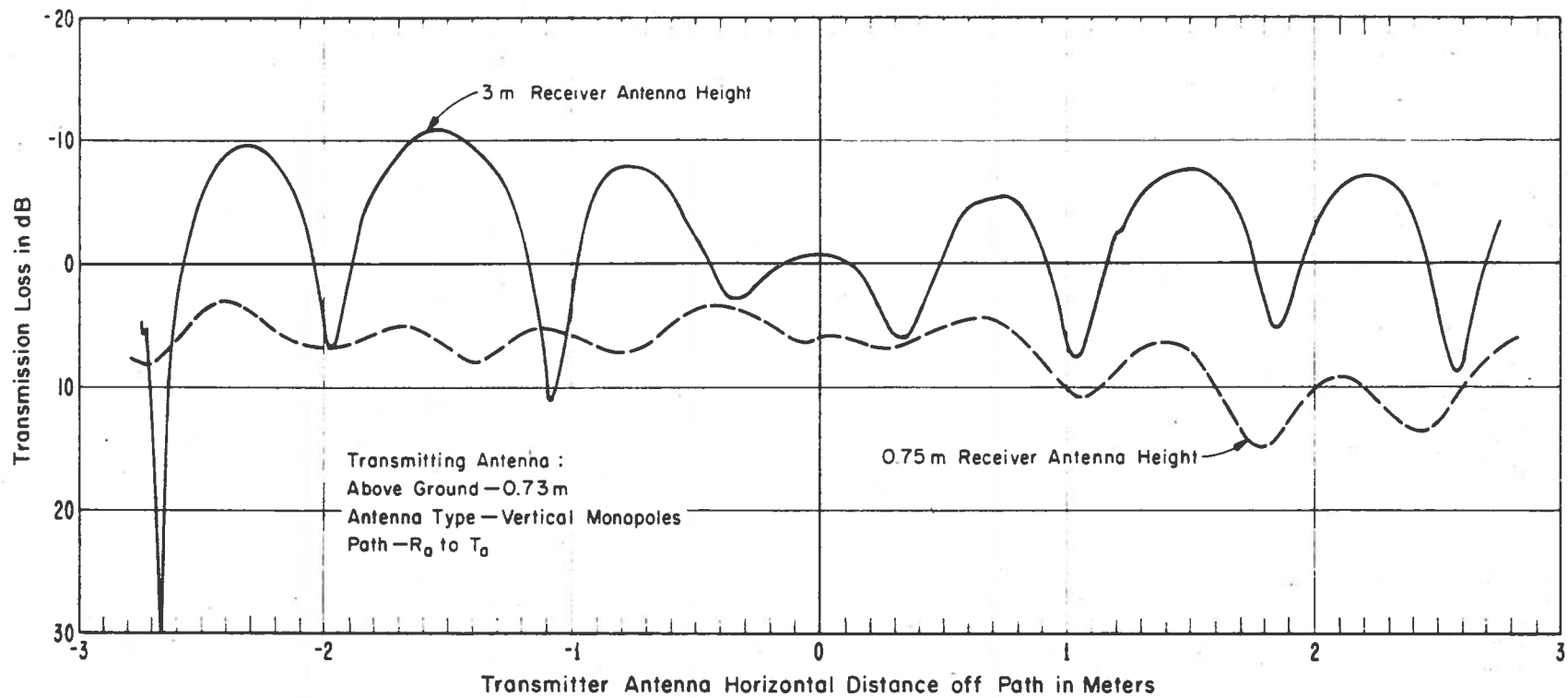

Figure 13. Investigation of reflection strengths and locations by means of a horizontal phase interference pattern along a line perpendicular to the path.

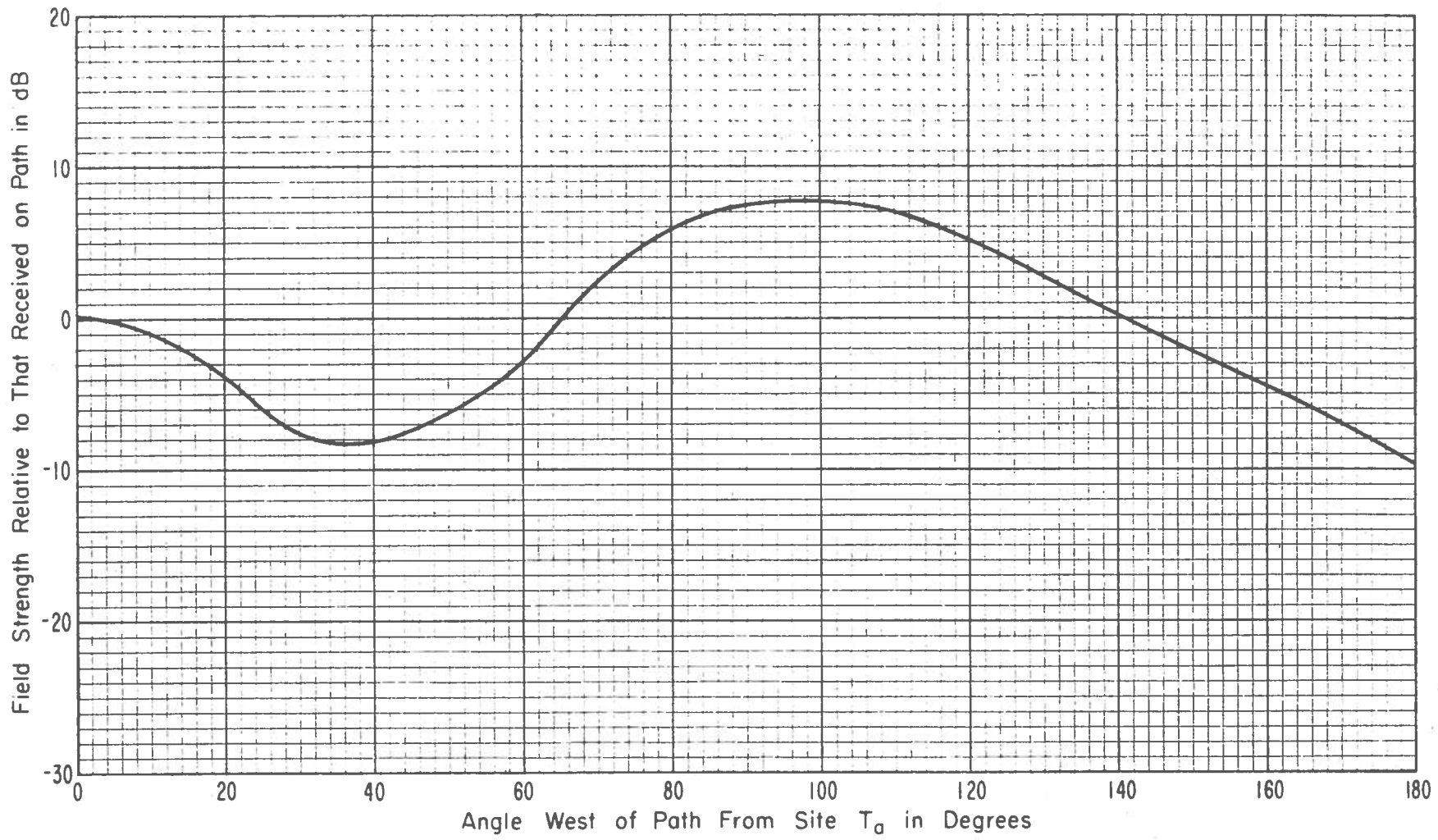
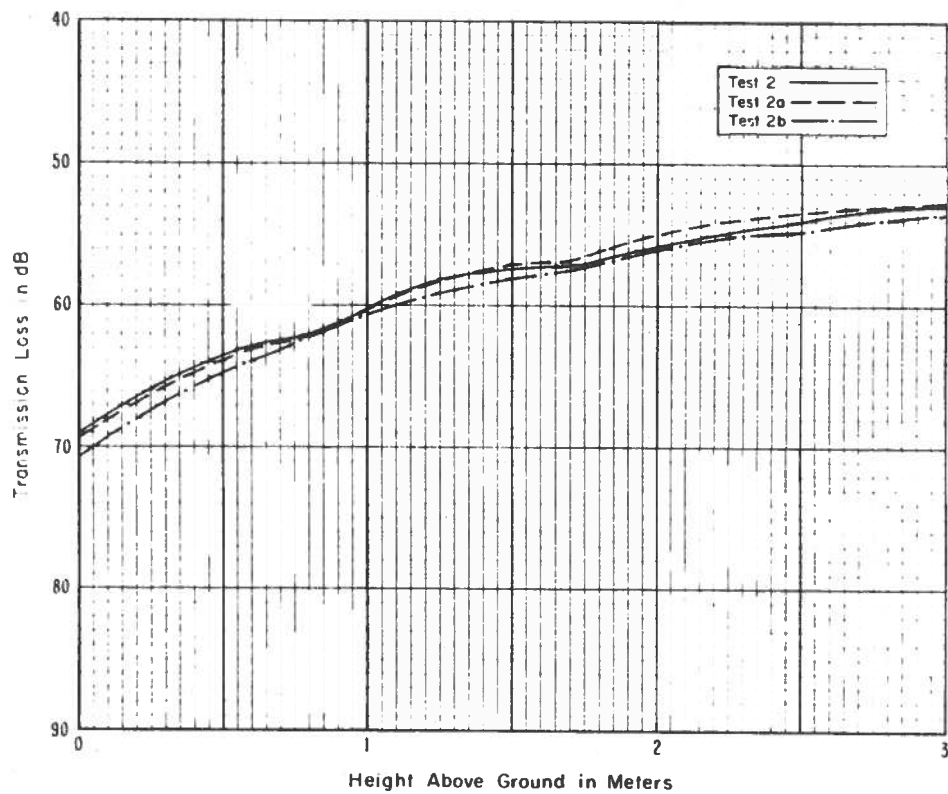
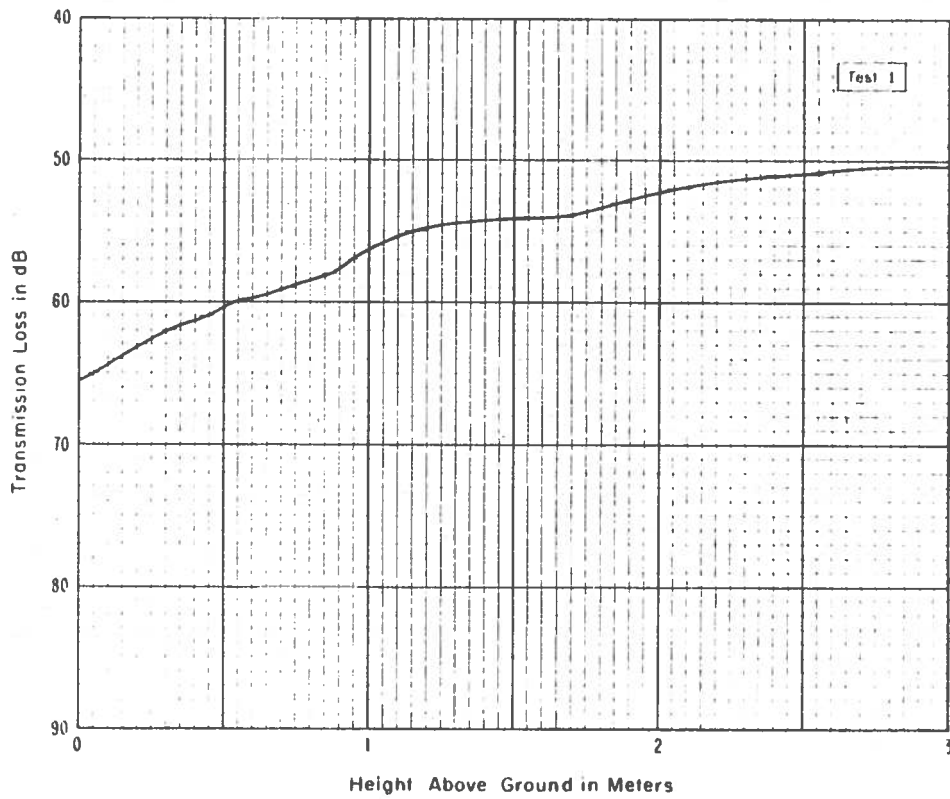
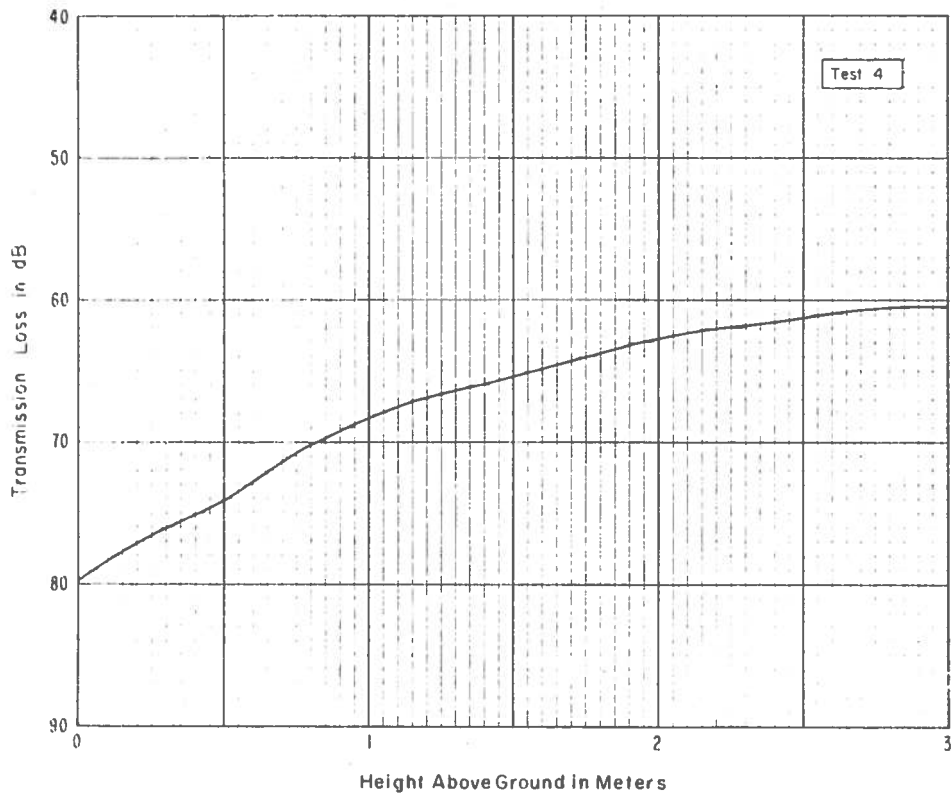
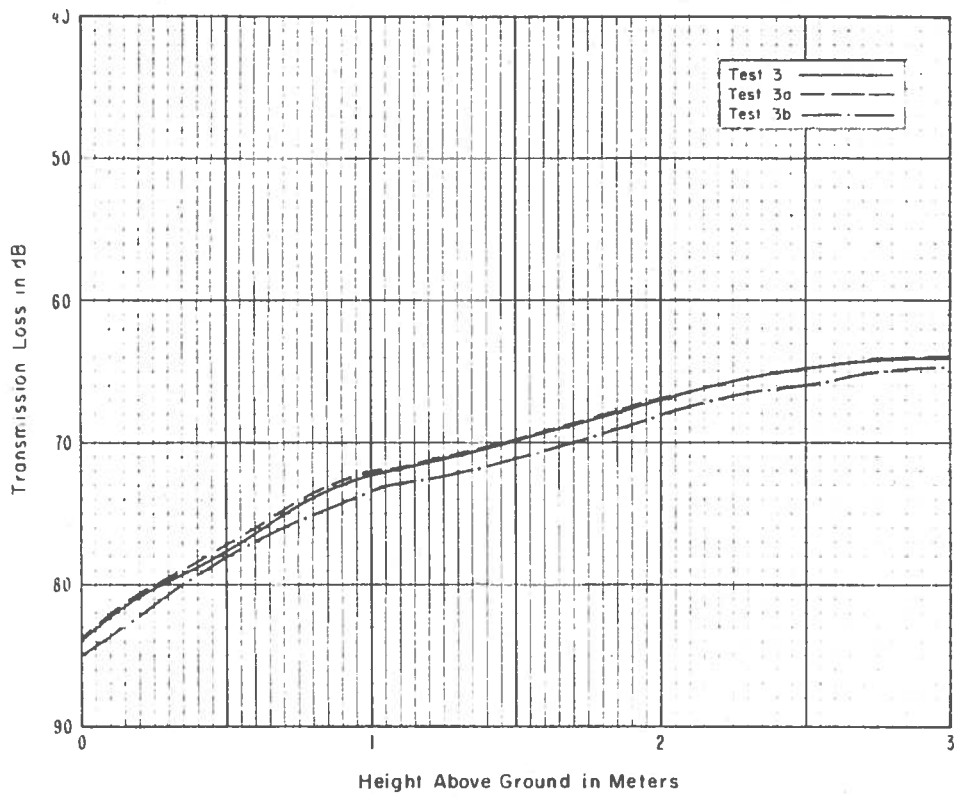
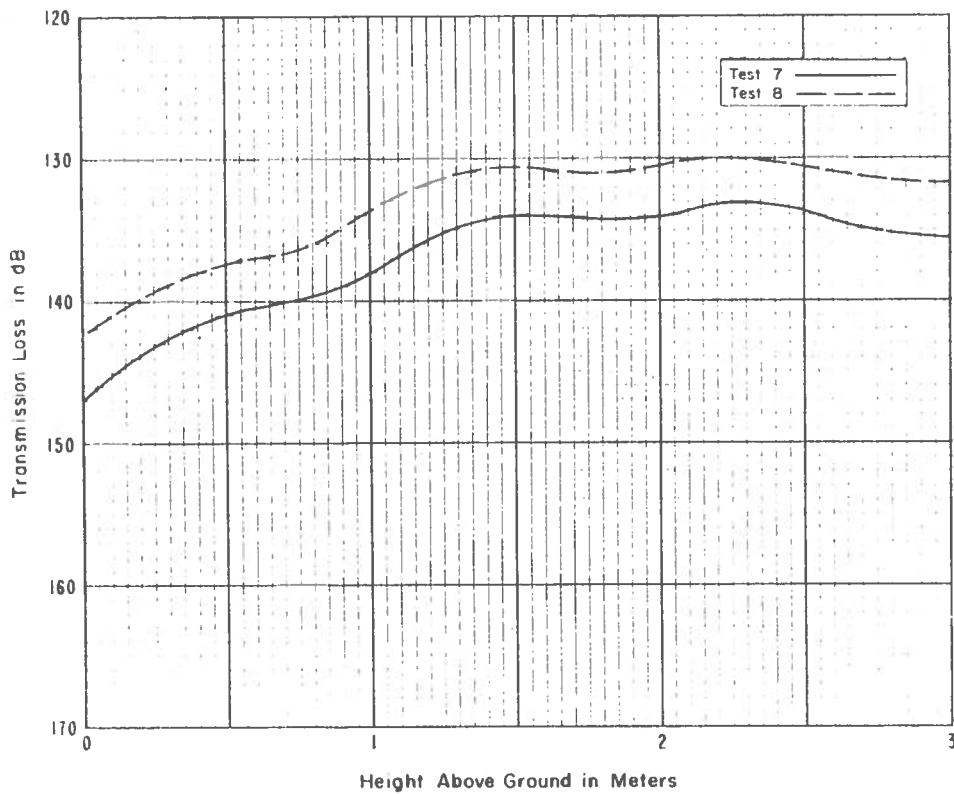
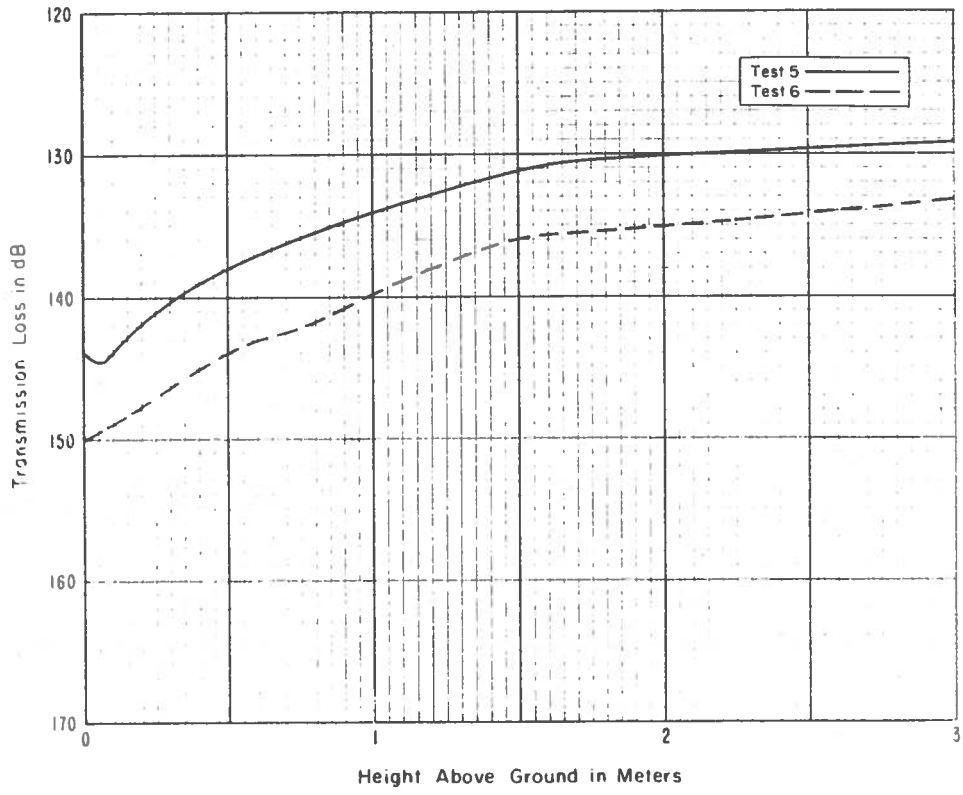
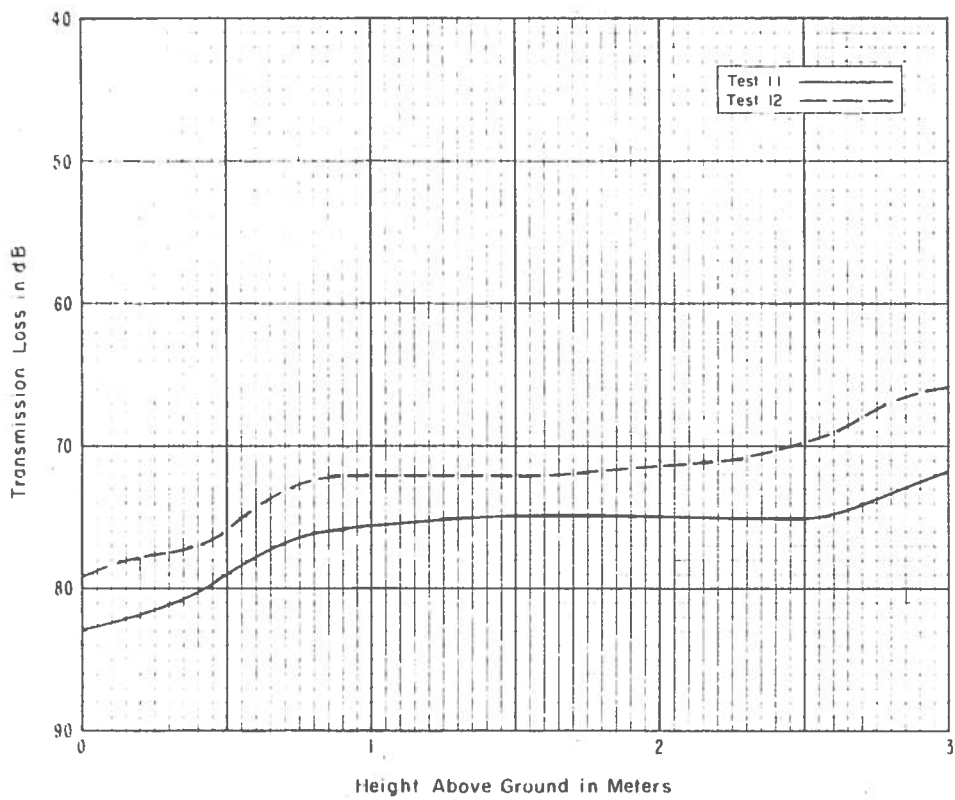
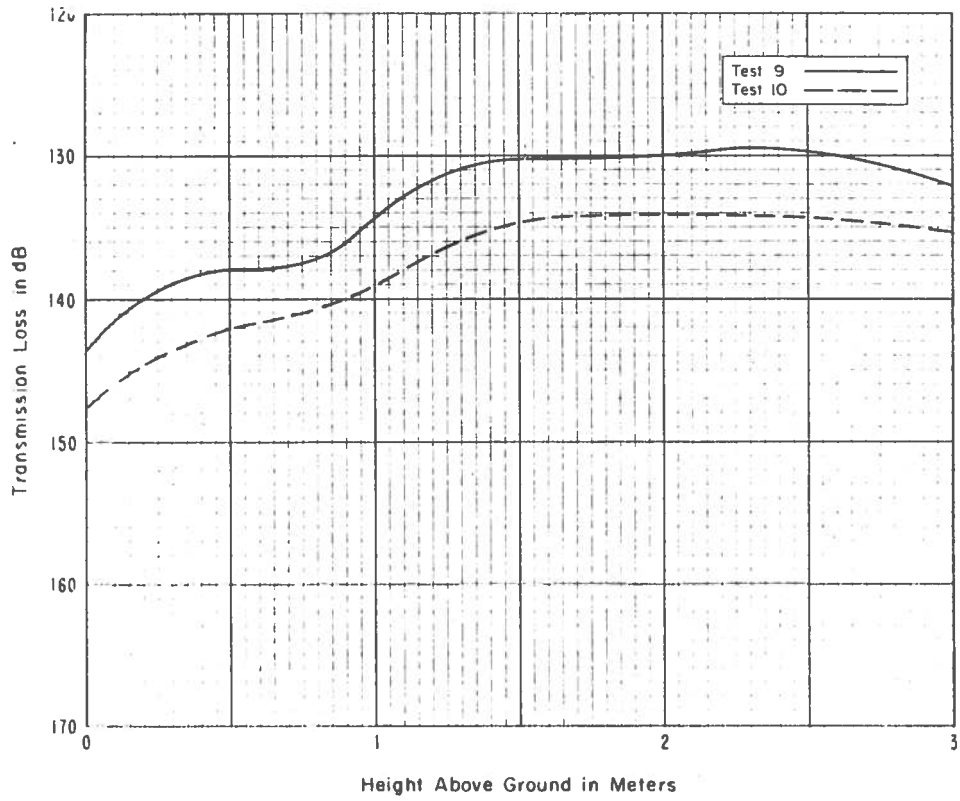

Figure 14. Directional antenna identification of secondary source locations









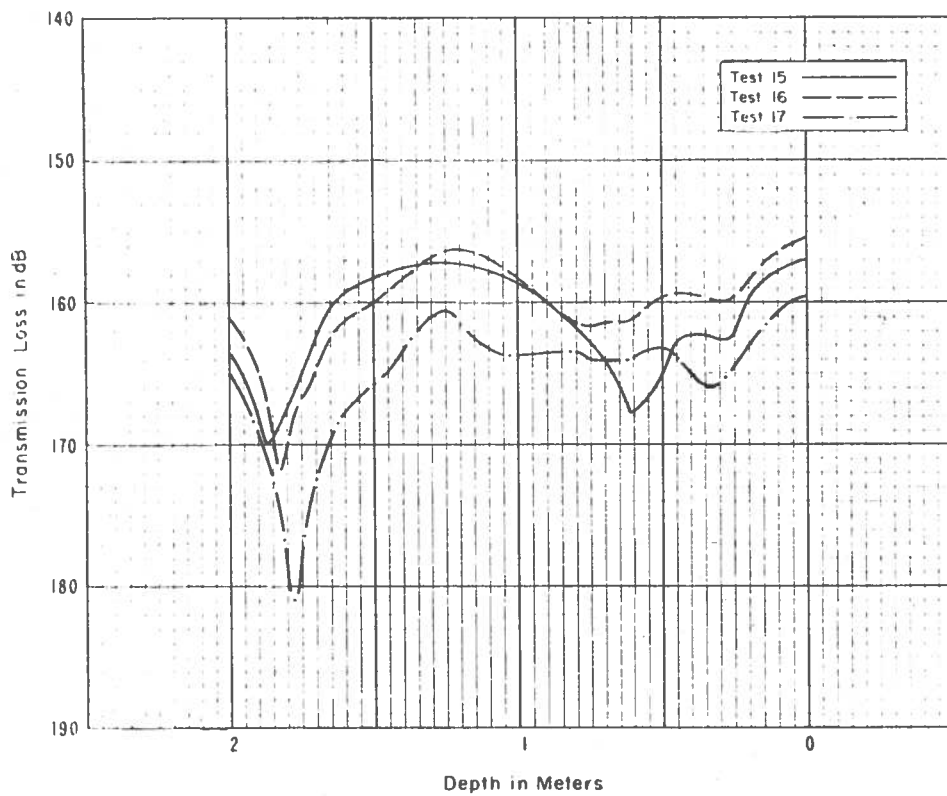
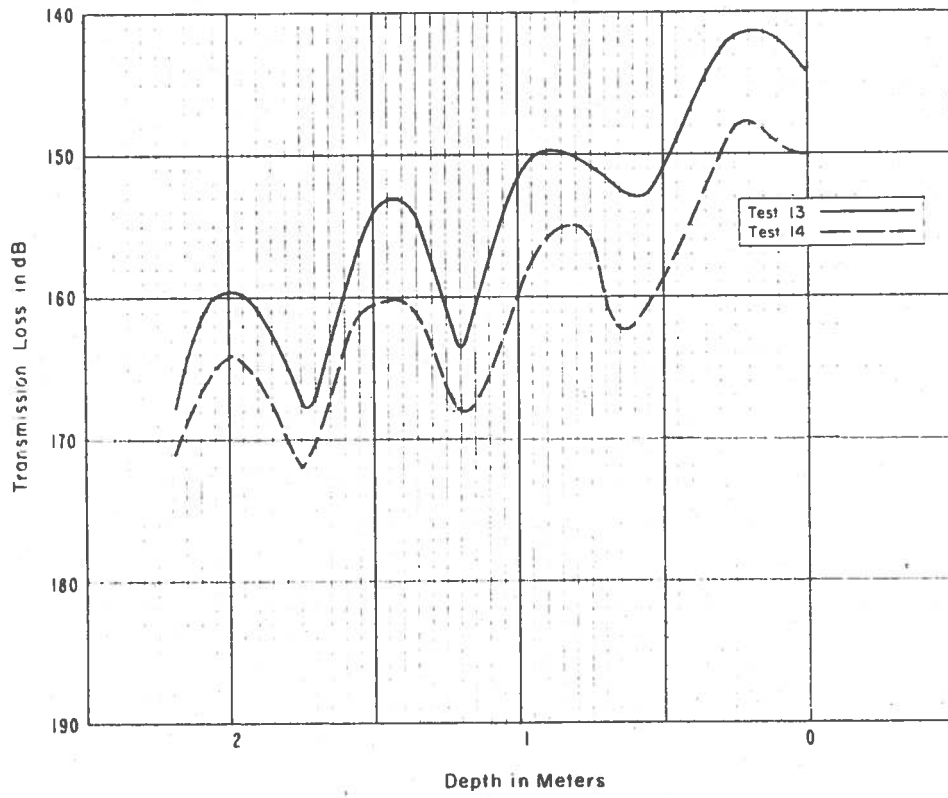

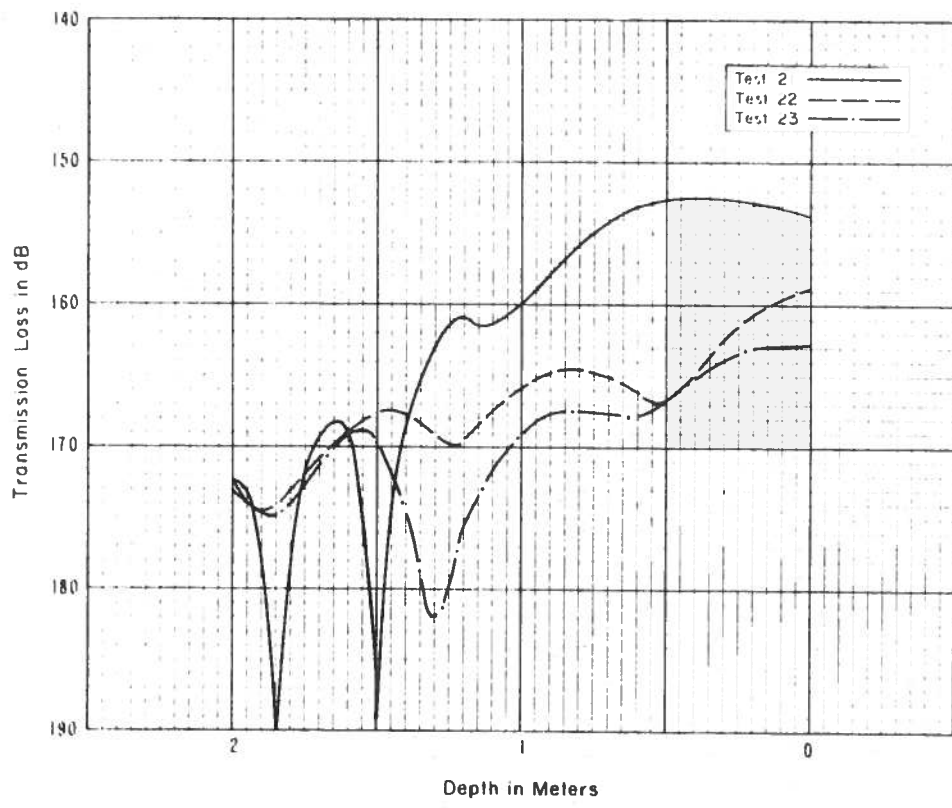
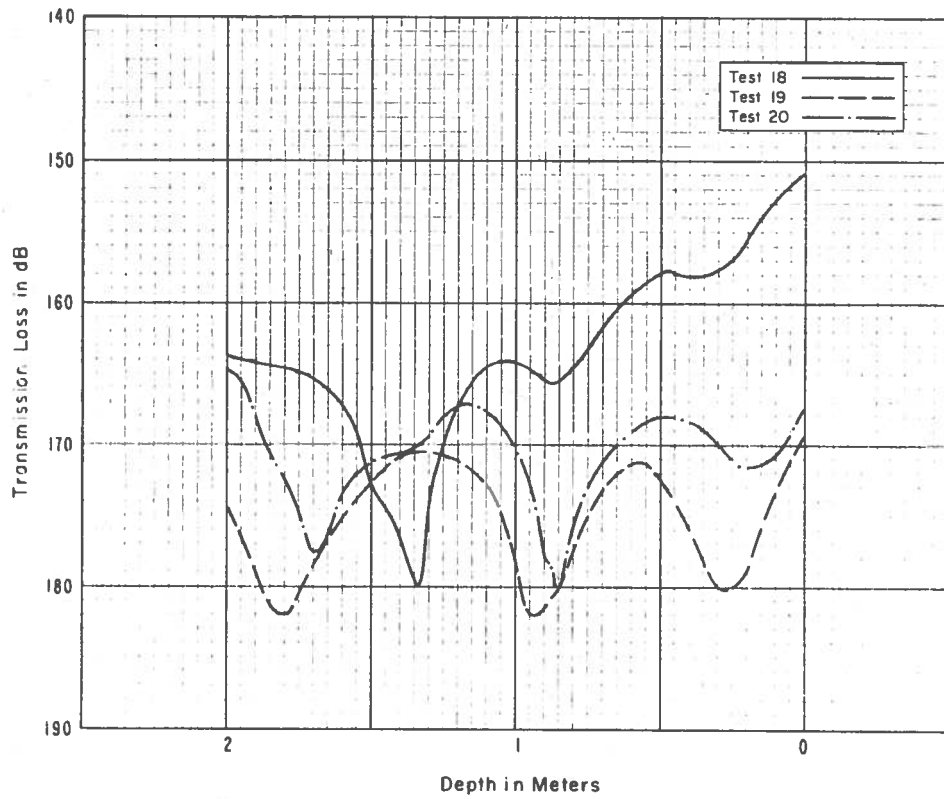

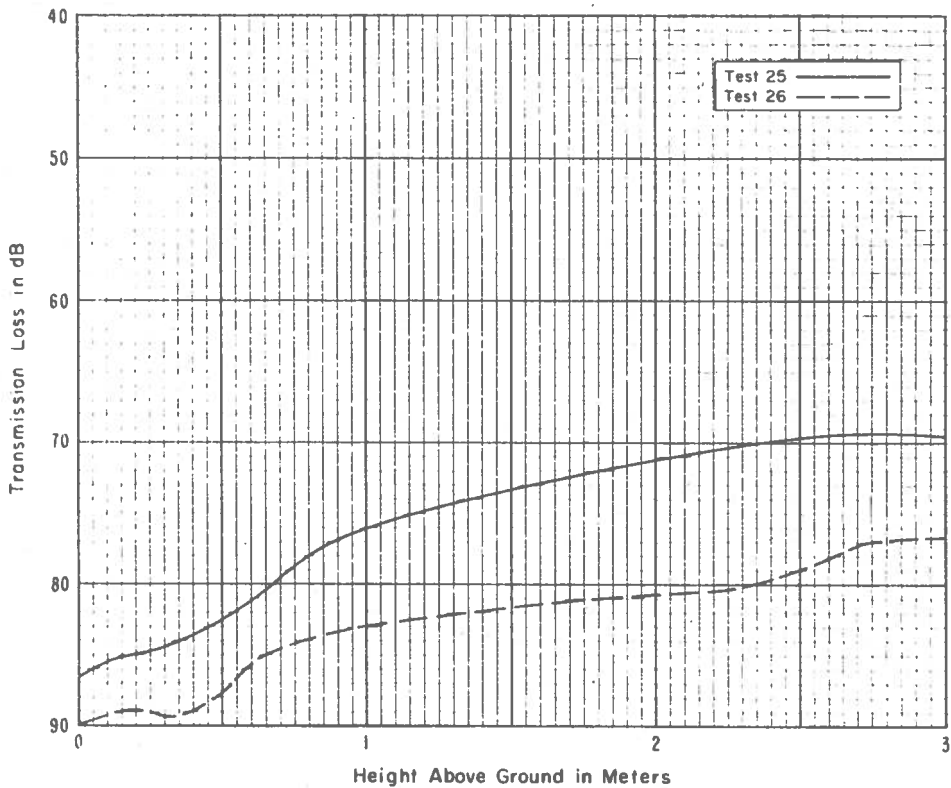
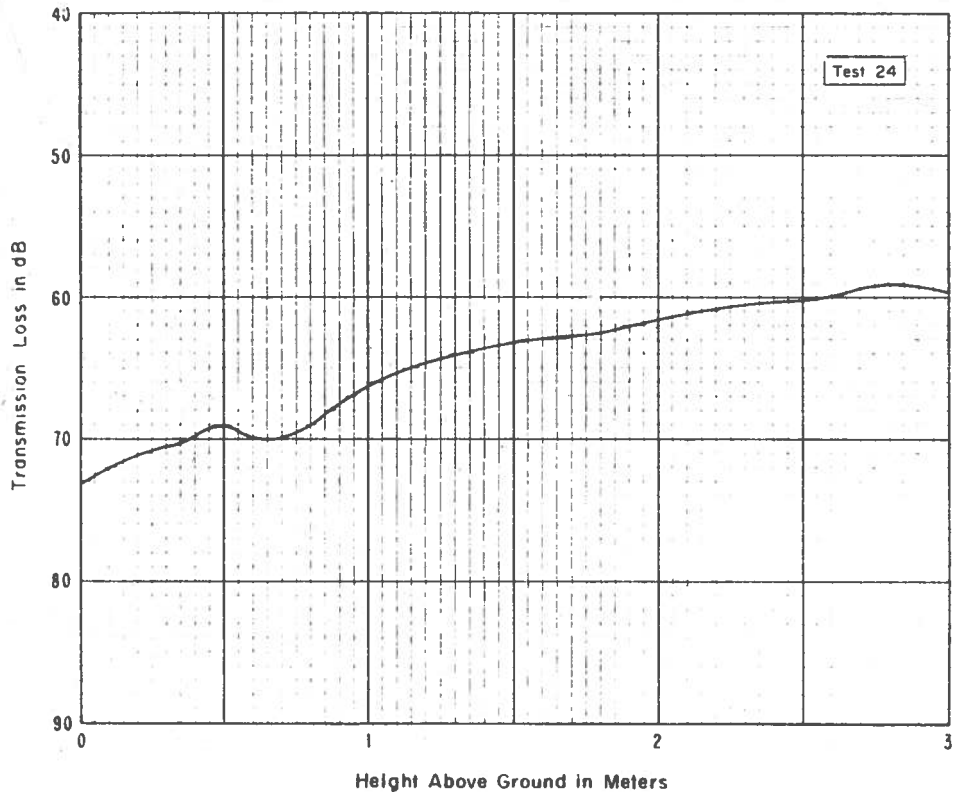

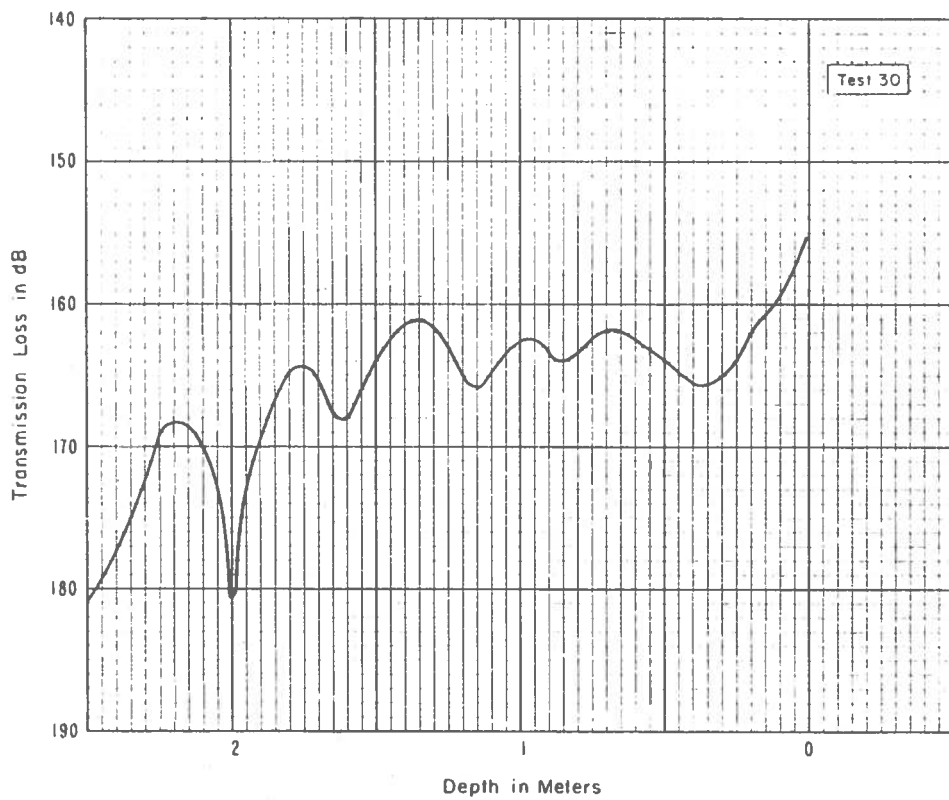
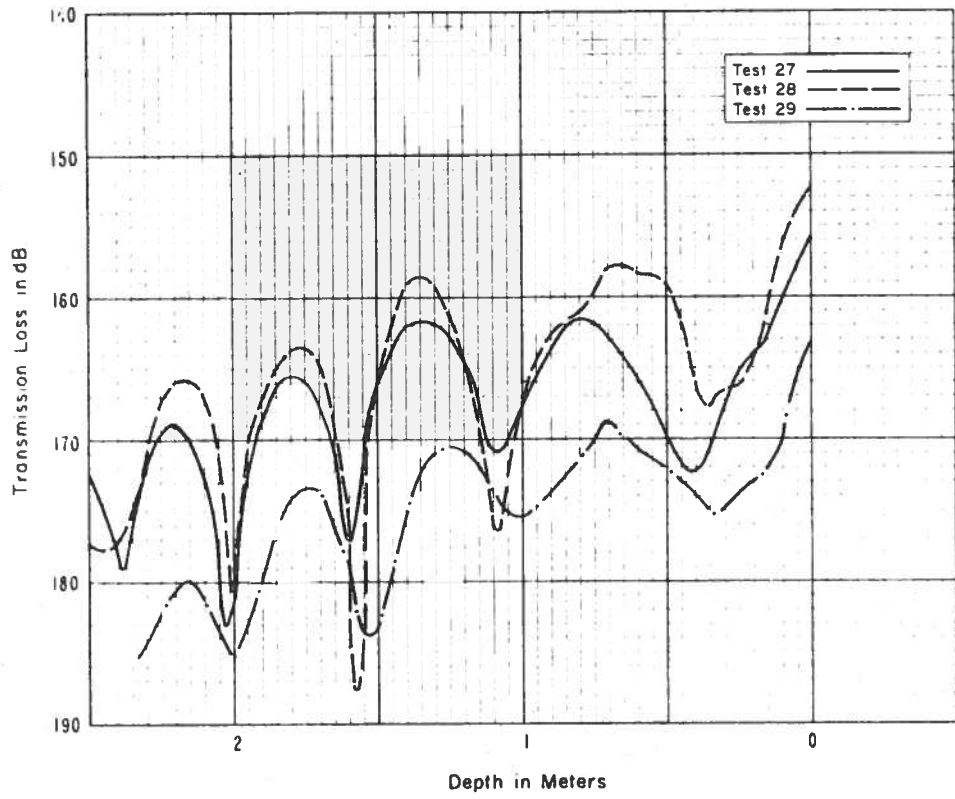

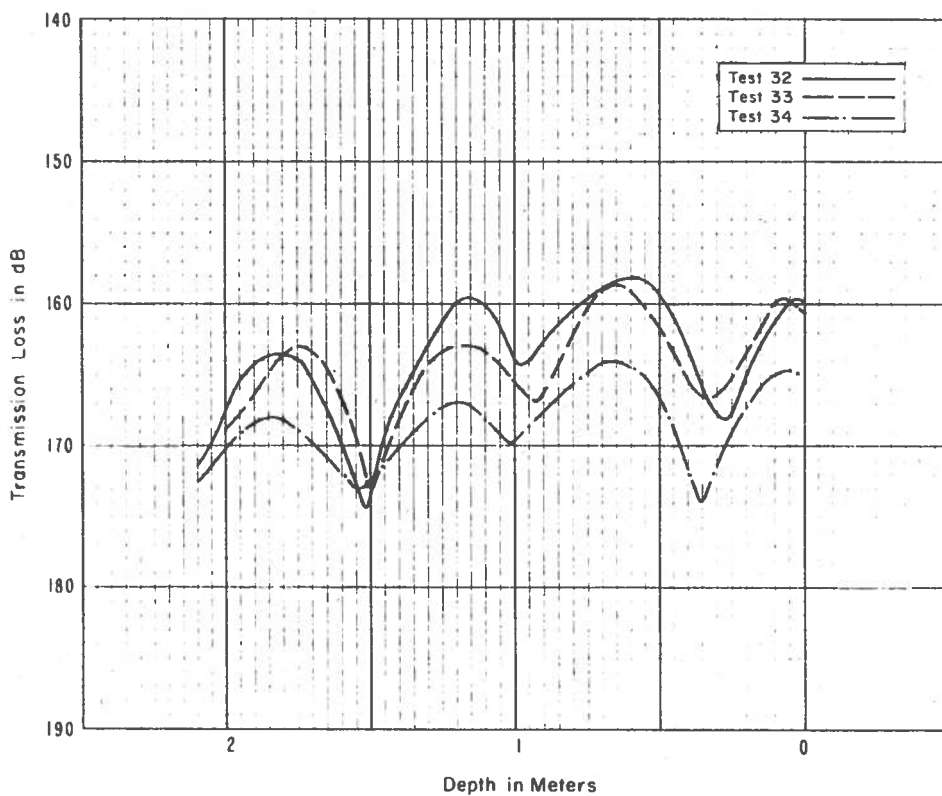
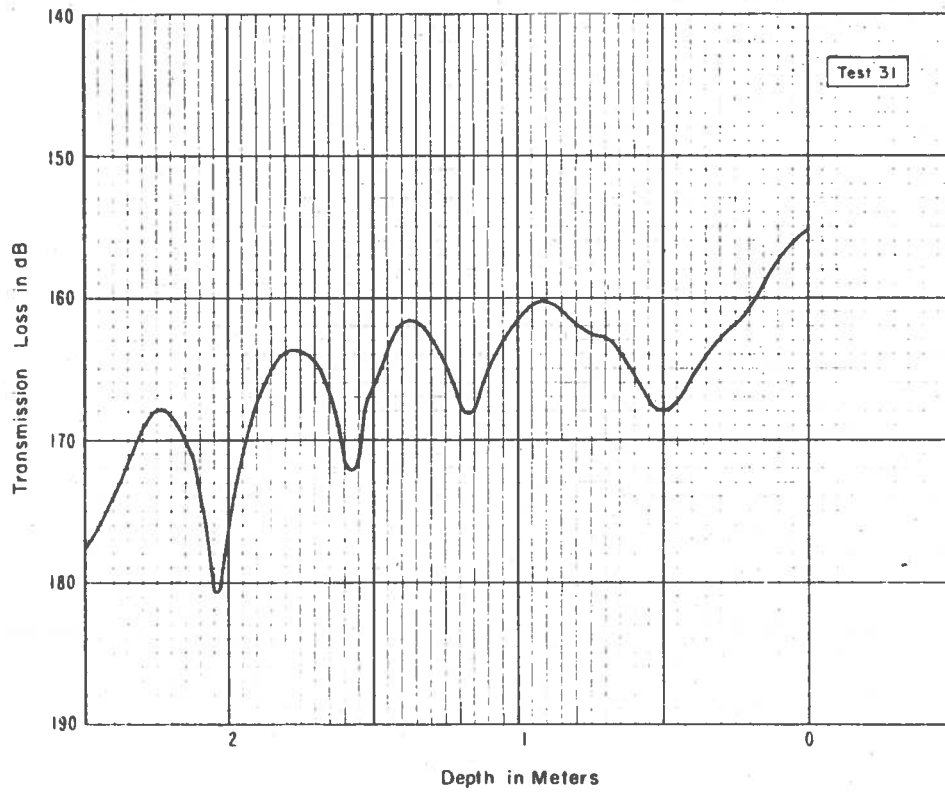

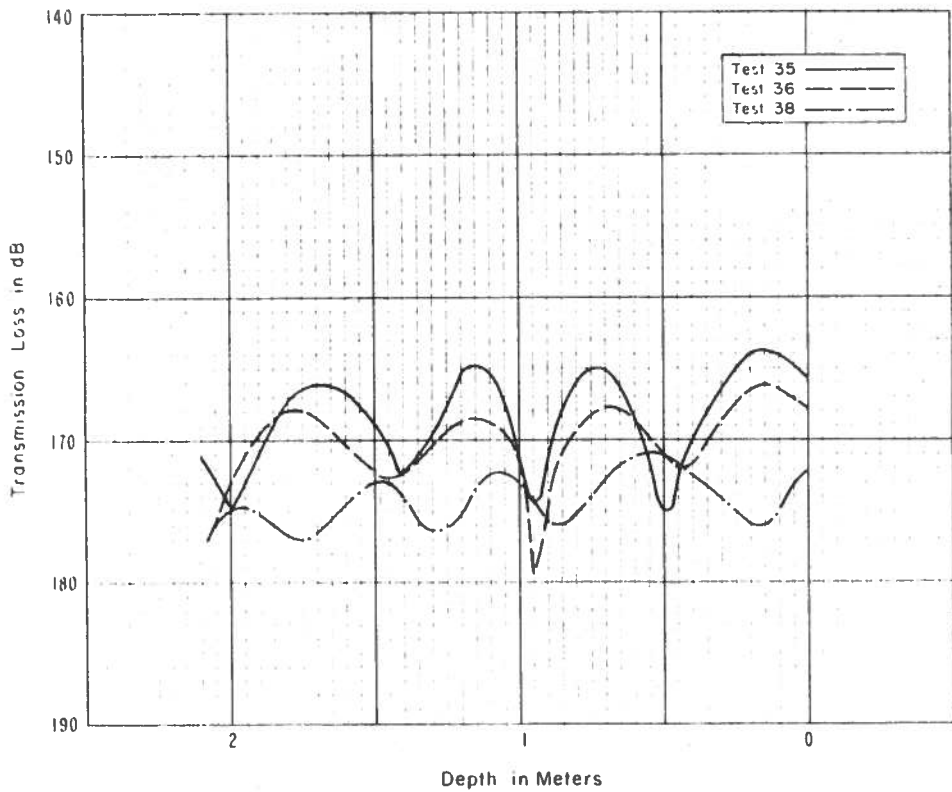
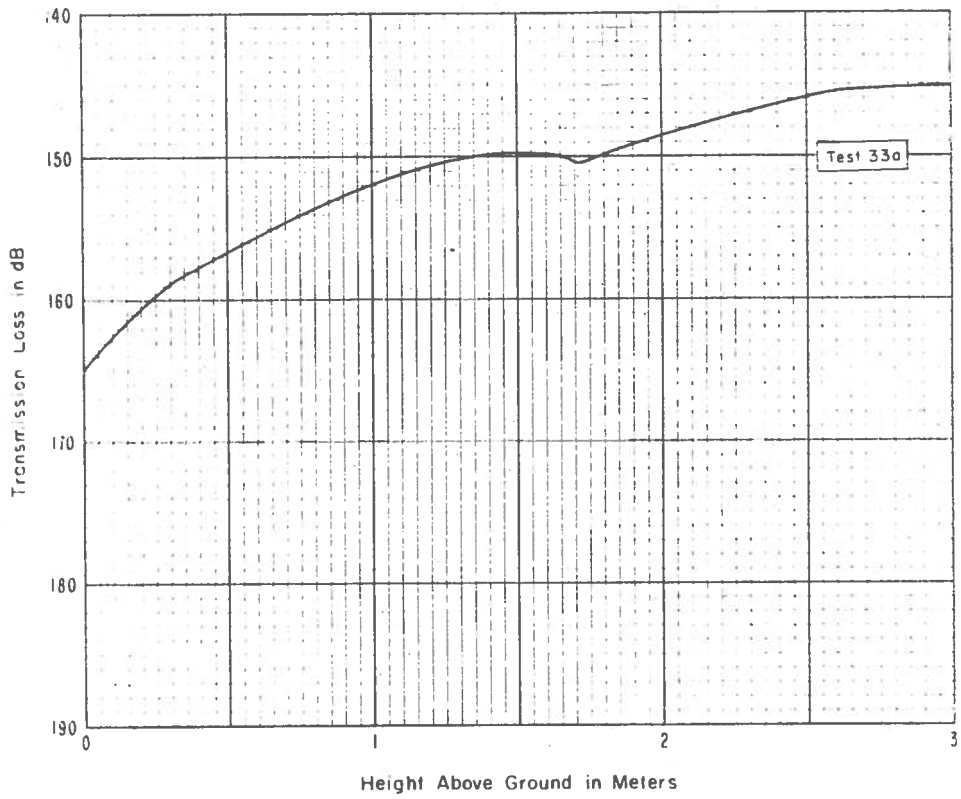

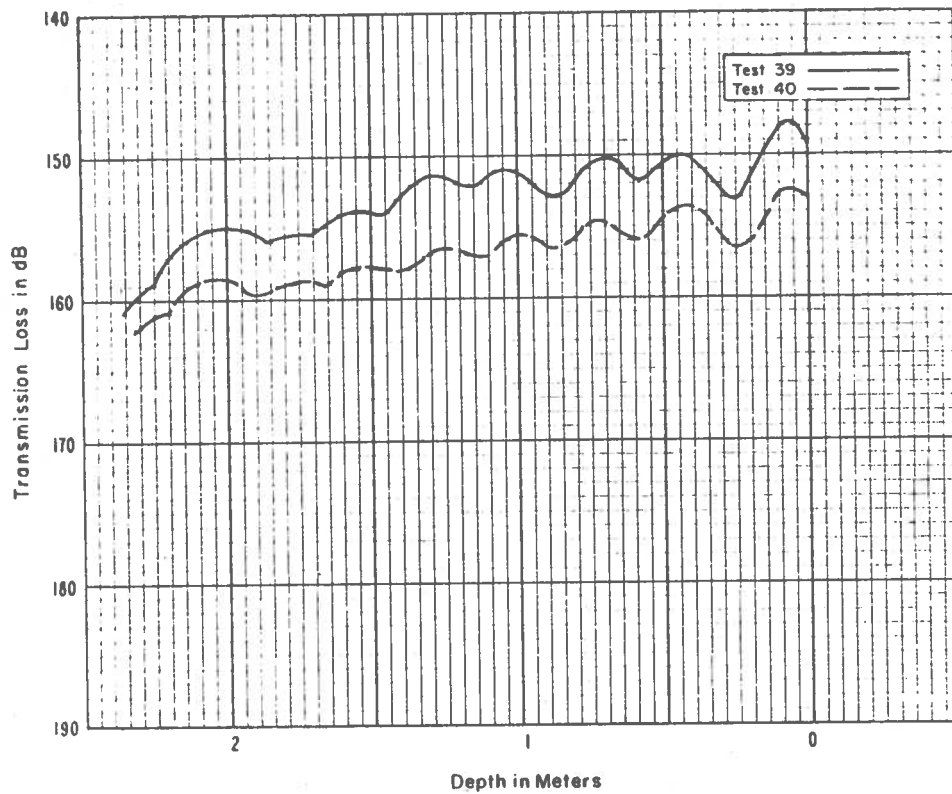
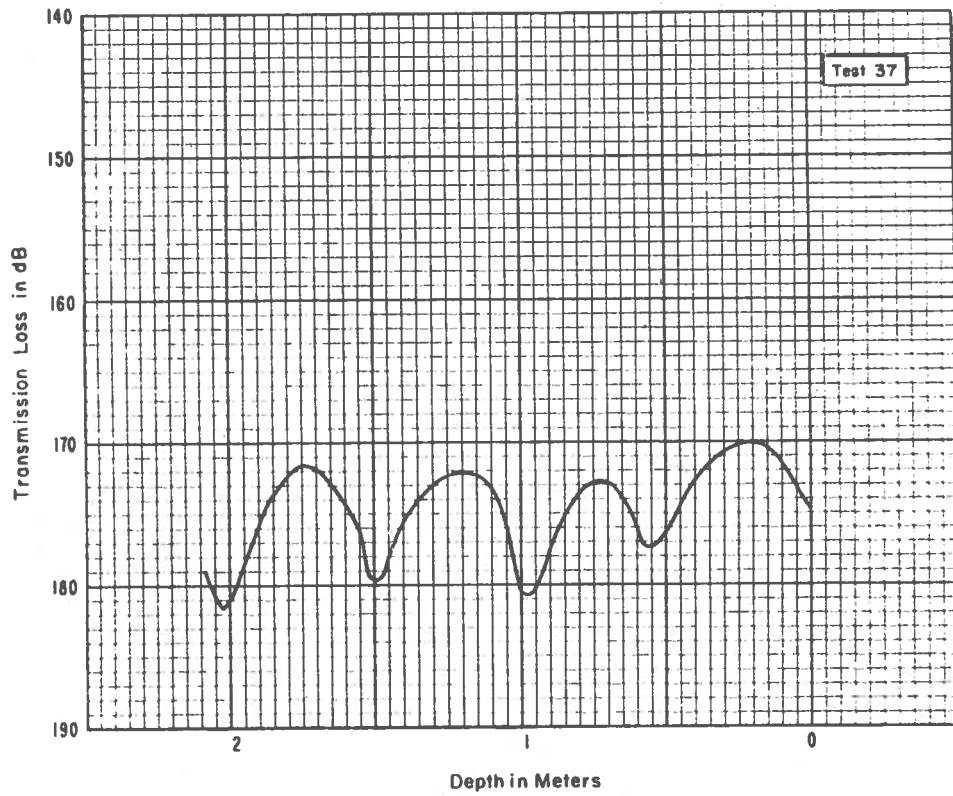

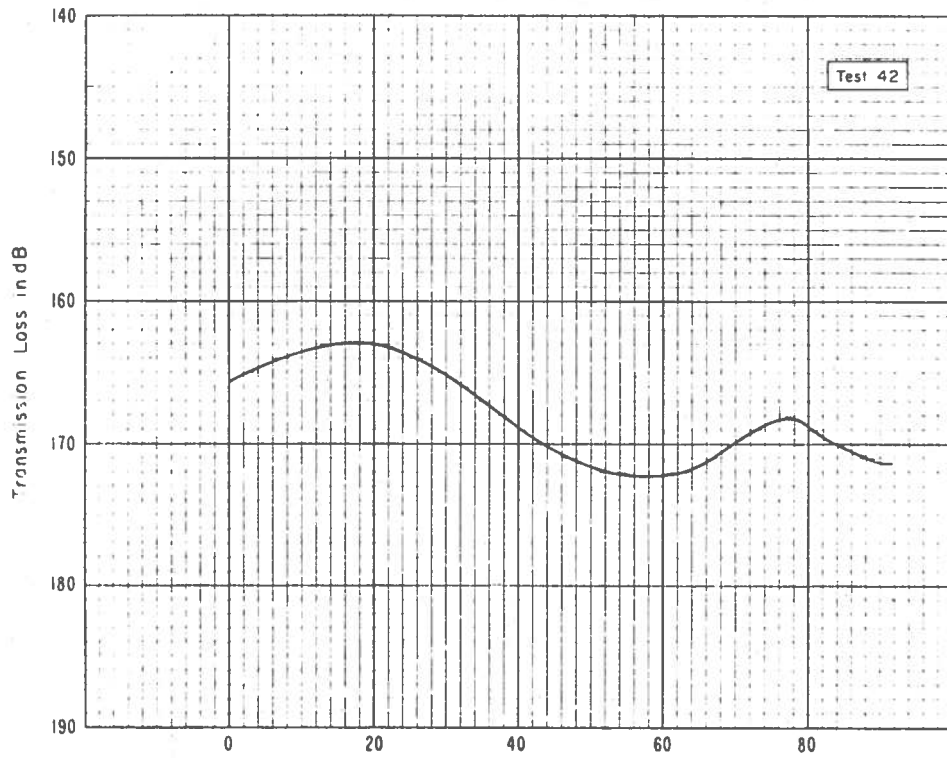

Angle between Horizontal Electric Dipole Antennas and the Path in Degrees.

APPENDIX

UHF Antennas for Subsurface Tests

Buried antenna tests at 415.9 MHz were made as reported by Hause et al. (1969) with a quarter-wave monopole (see figs. 1, 4, and 7). Additional buried antenna tests at this frequency with an annular slot antenna and an electric dipole were made. These antennas, shown in figures 2 and 3, were chosen for investigation because of their more desirable, and simple, radiation patterns. The theory and construction of the annular slot antenna is described by Bolljahn and Granger (1961) and Terman (1955). To increase the bandwidth of the annular slot antenna, the slot was fed with a tapered transmission line. Measurements were made to obtain the VSWR while the antenna was buried under rock. This was done by inverting the slot antenna over asphalt paving and then over dry bare ground. The VSWRs measured were 1.55 and 1.47. The dipole antenna (fig. 5) was designed to provide equally good impedance matches in both air and rock at 415.9 MHz. In air, the dipole is 0.44 wavelength long.

Vertical pattern measurements were made for each of the three types of antennas by rotating them from -90° to $+90^{\circ}$; the mechanism used for rotation is shown in figure 3. The radiation patterns are shown in figures 7 through 10. The data obtained indicated maximum antenna gains to be 2.4, 2.7, and 3.7 dB above isotropic for the stub, dipole, and annular slot antennas respectively. Note that the vertical pattern for the sleeve dipole antenna (fig. 8) is somewhat a symmetrical, a deviation attributable to the antenna feed line. For buried antennas, the gains at the high elevation angles (60° to 90°) are of most interest. Between the elevation angles of 60° and 80° , the annular slot antenna in air provides approximately 14 dB greater gain than the stub antenna. Radiation patterns can partly be simulated to "below ground" conditions by using a frequency approximately twice the antenna design frequency. This test was accomplished for the annular slot antenna by making measurements at 920 MHz. The pattern is shown in figure 10.

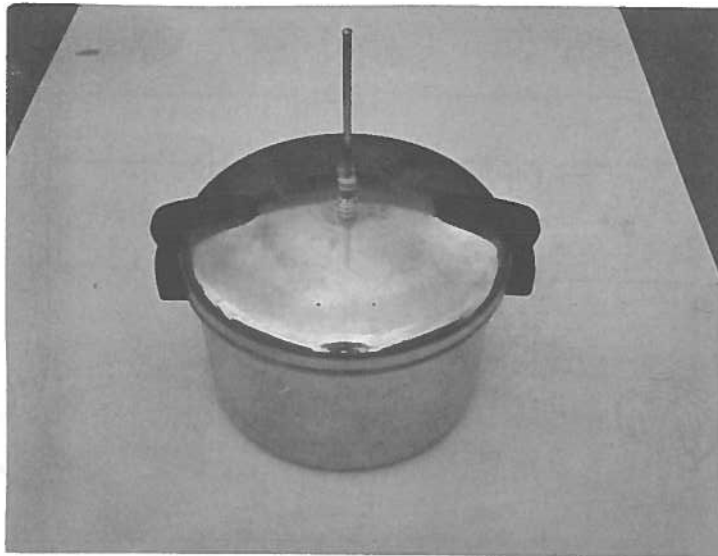

Figure A 1. Monopole antenna.

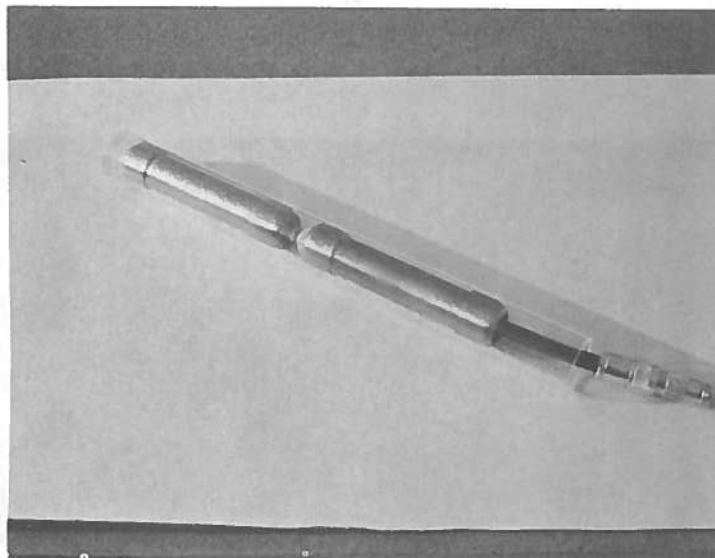
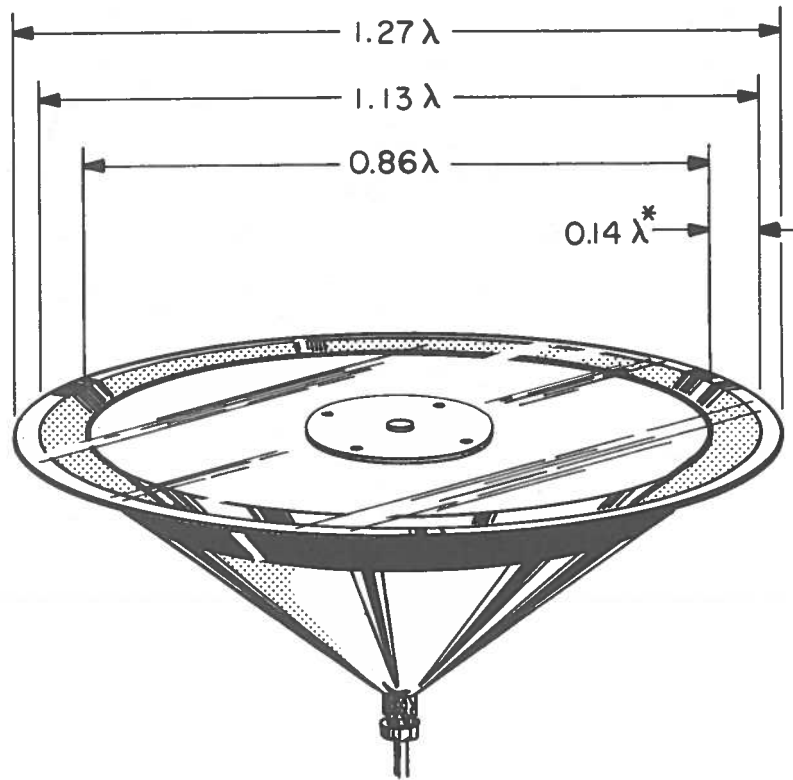

Figure A 2. Dipole antenna.



* λ = One Wavelength in Air



Figure A 3. Annular slot antenna.

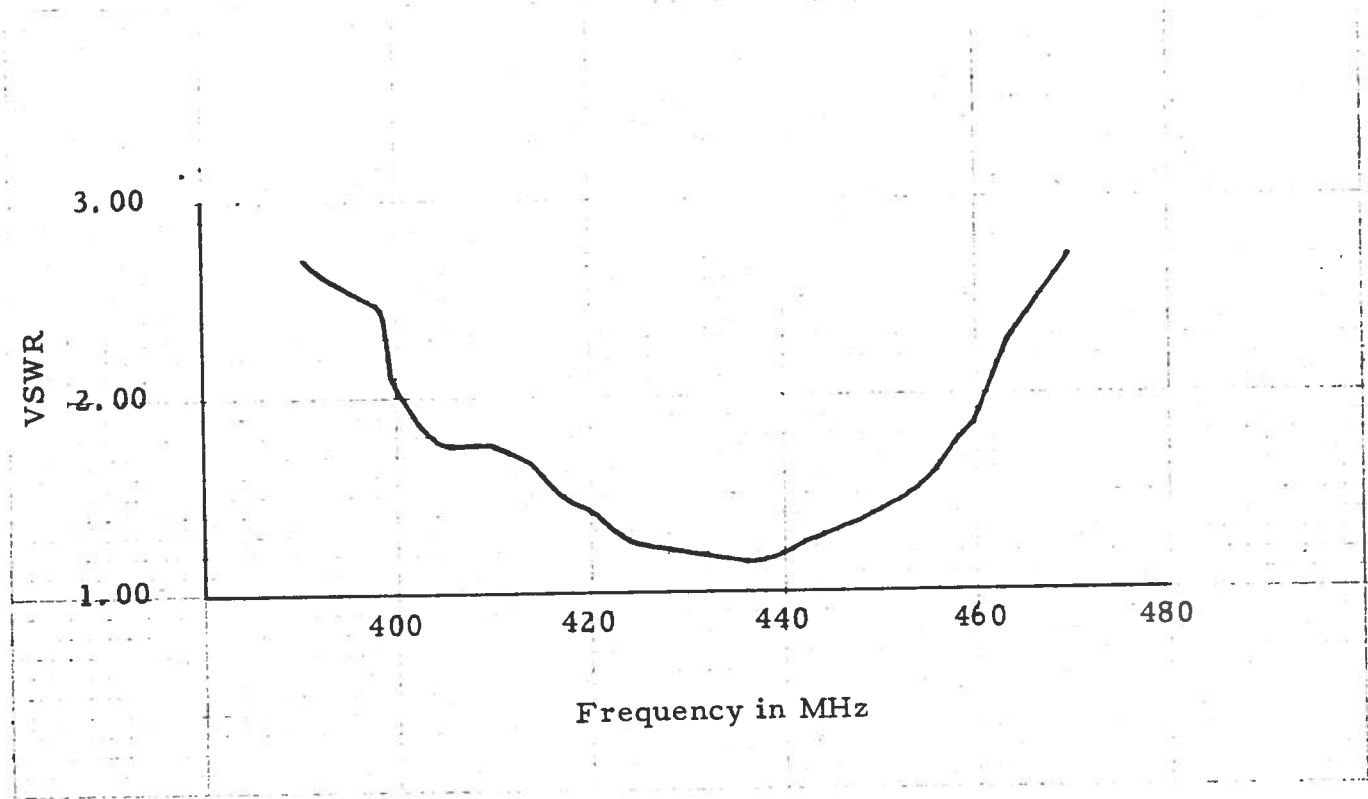

Figure A 4. Impedance characteristic of the stub antenna in air.

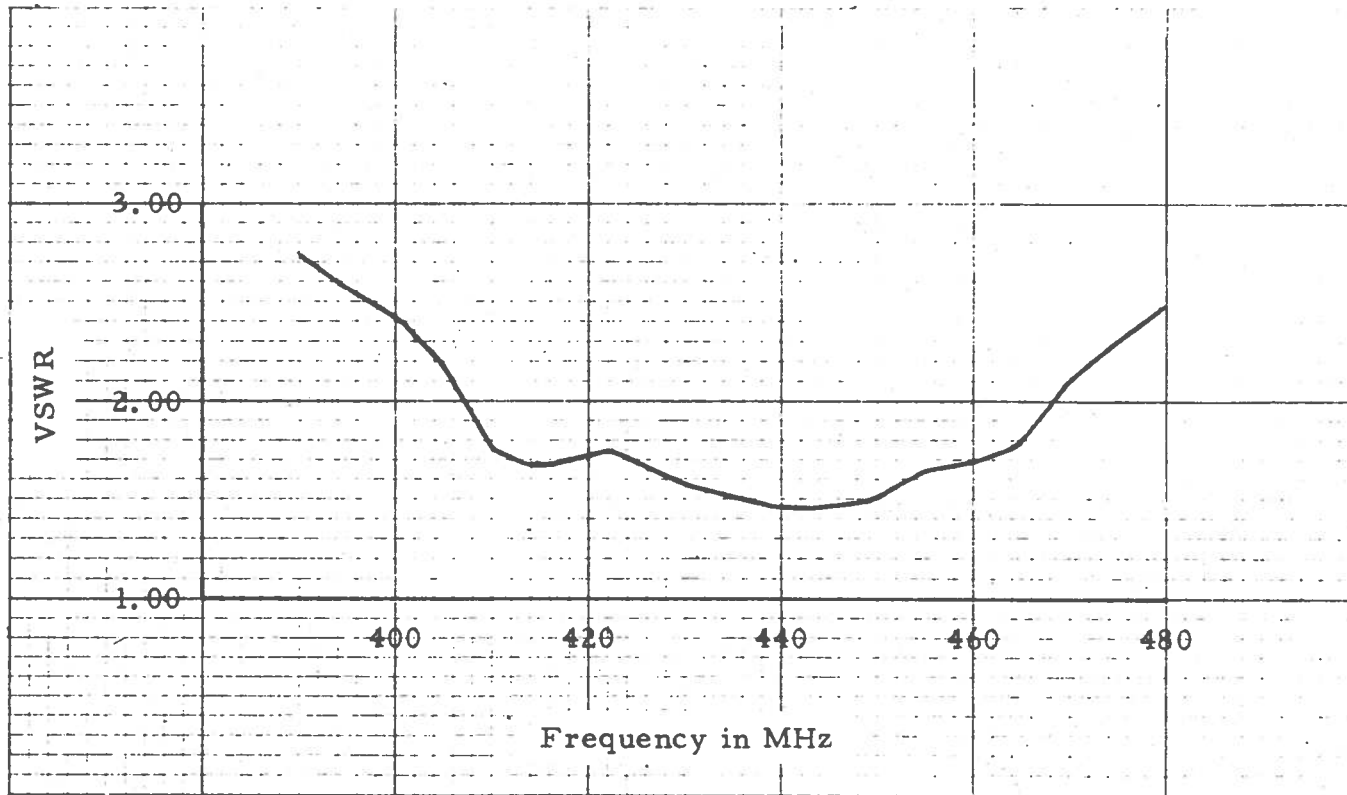

Figure A 5. Impedance characteristic of the dipole antenna in air.

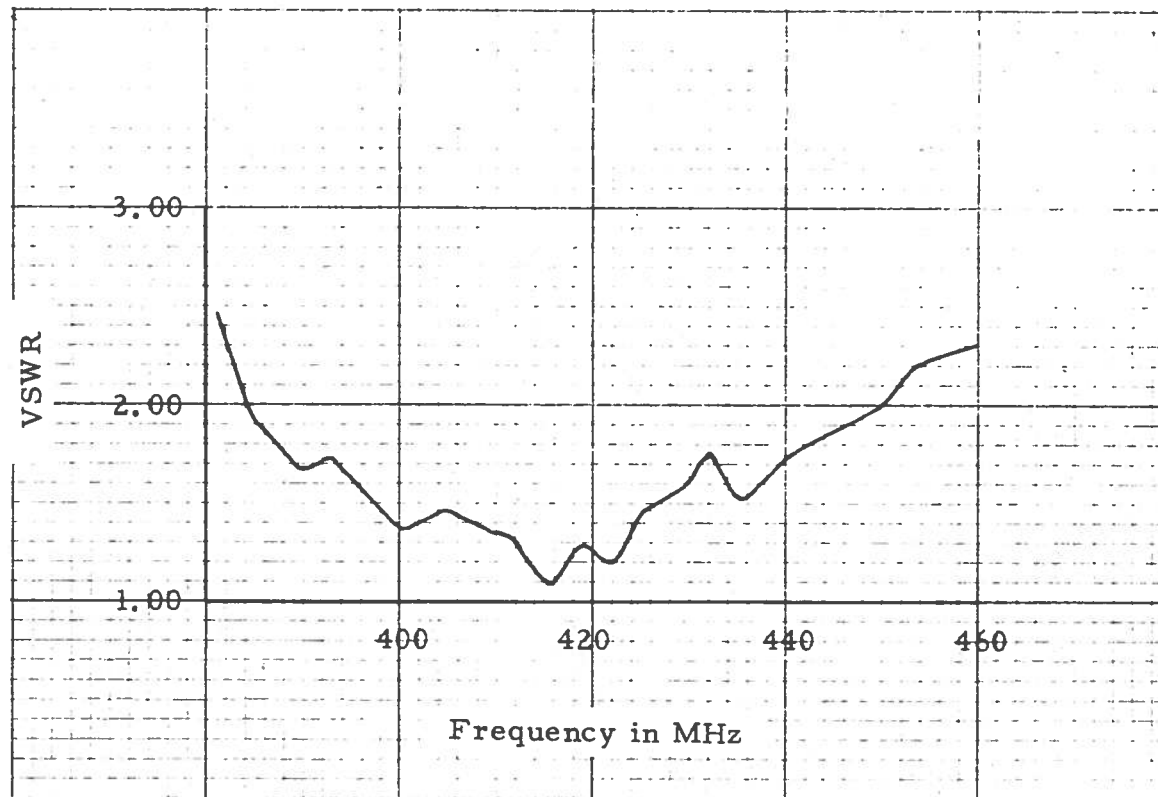

Figure A 6. Impedance characteristic of the annular slot antenna in air.

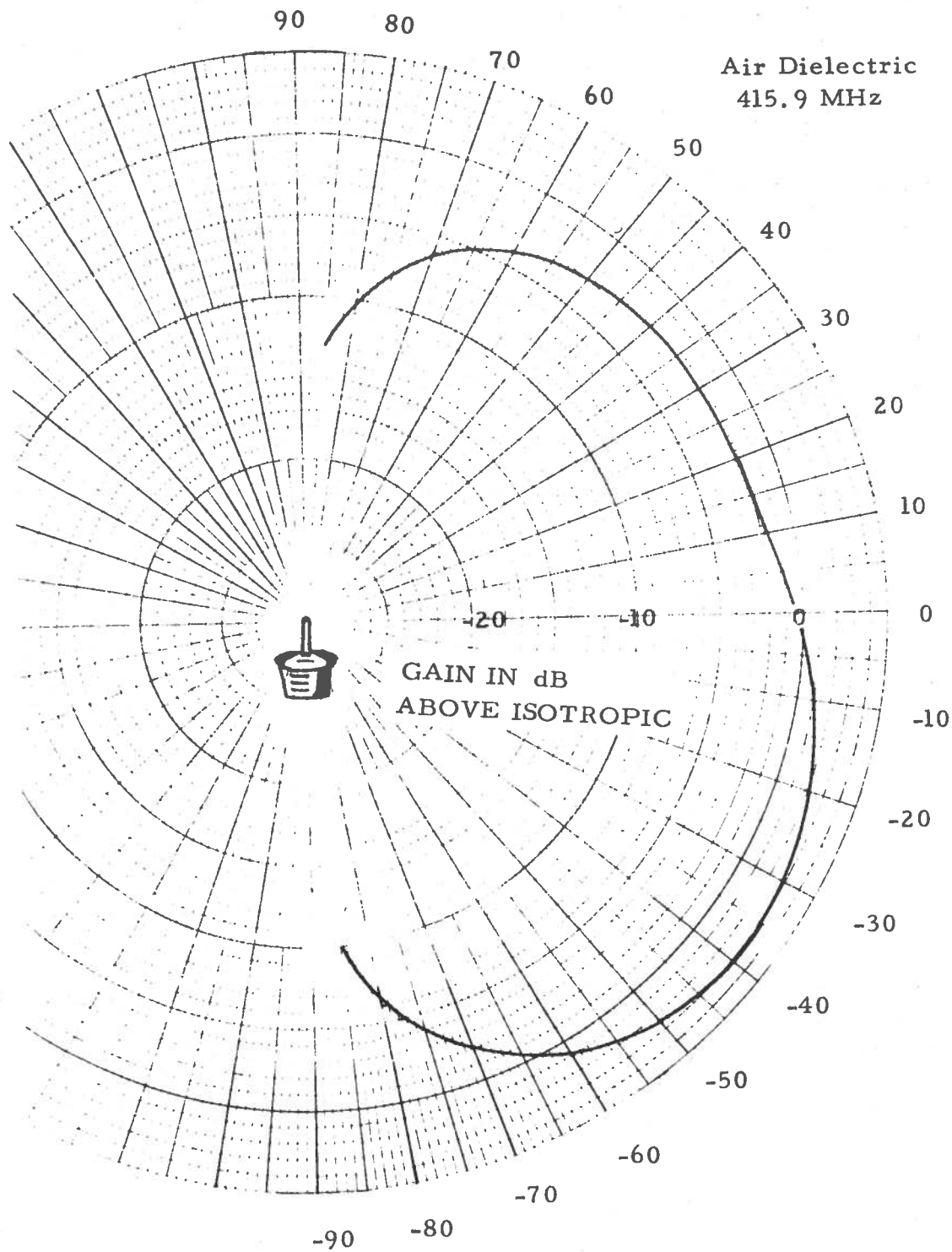

Figure A 7. Stub antenna vertical pattern.

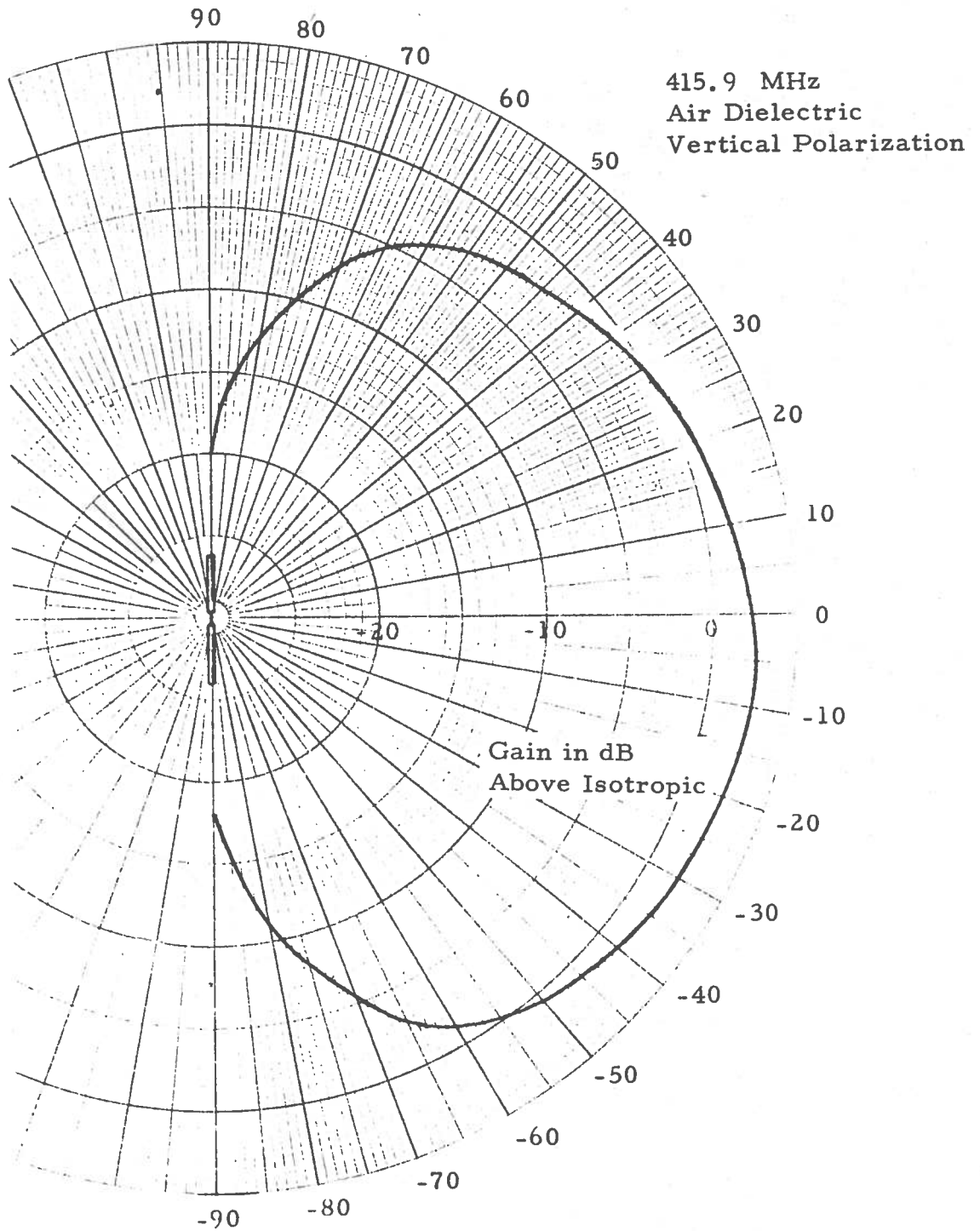

Figure A 8. Dipole antenna vertical pattern.

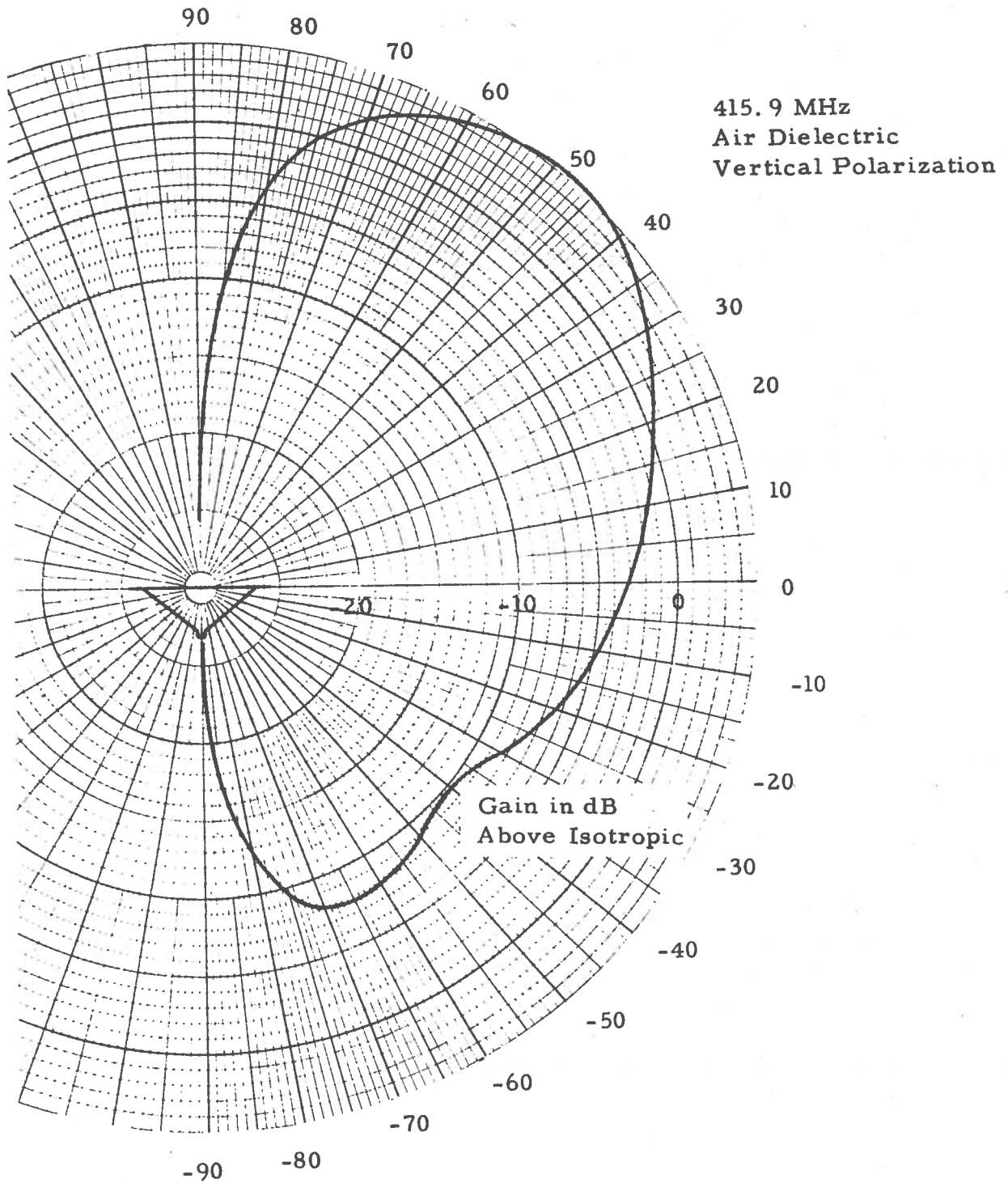

Figure A 9. Annular slot antenna vertical pattern at 415.9 MHz

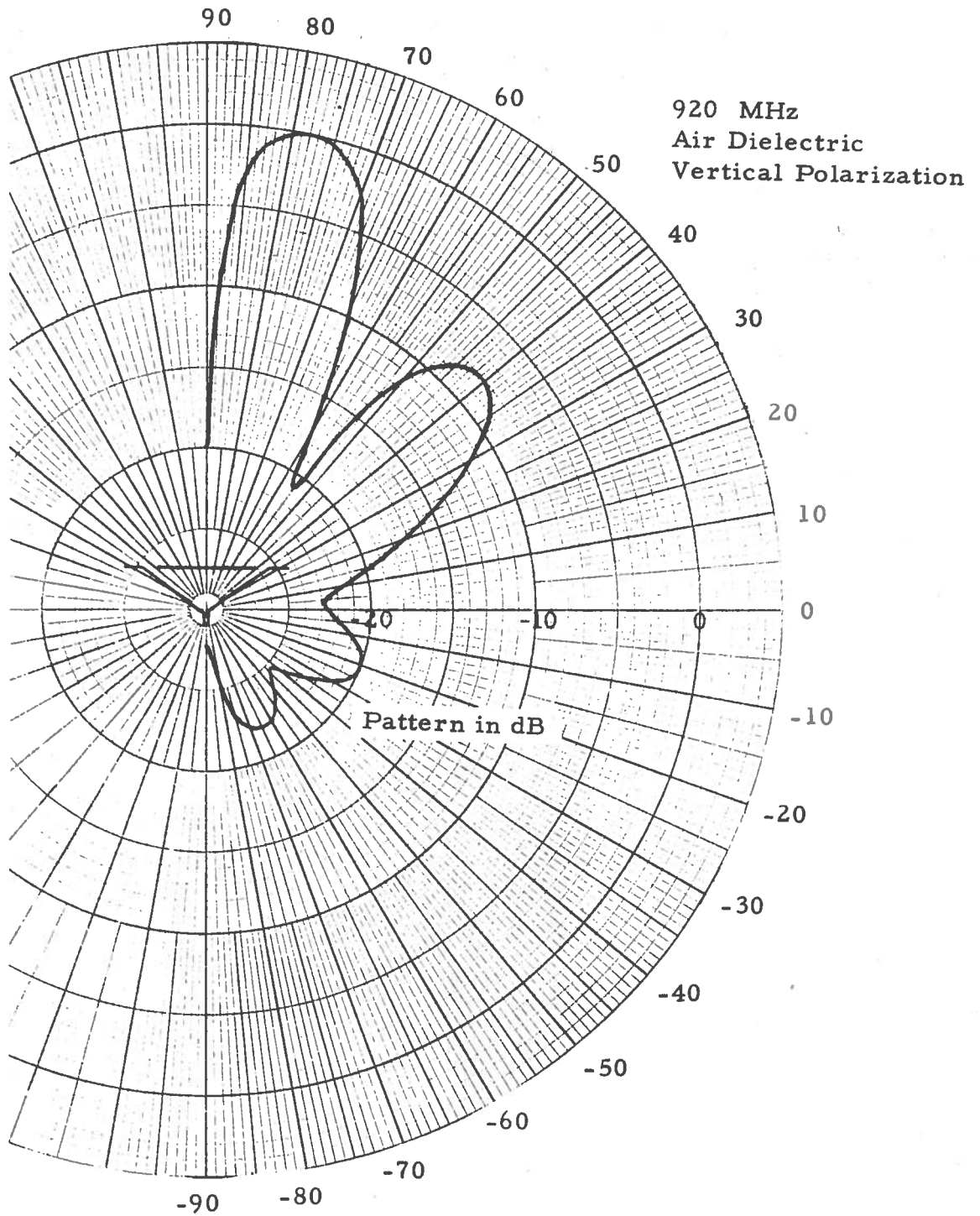

Figure A 10. Annular slot antenna vertical pattern at 920 MHz.

